

WORKCENTER ACCESSORIES

PRODUCTION BOOSTERS

- CAN BE USED ON ANY WORK BENCH
- HANDS OFF USE FOR MANUALS AND INSTRUMENTS
- SHELVES ADJUST TO ANY ANGLE, TIP TOWARD FRONT OR BACK
- SAFELY HOLDS EXPENSIVE TEST EQUIPMENT
- CAN TRIPLE WORK SURFACE

MODULAR DRAWER CABINET, CLOSED LEG, PEDESTAL, IRON-1 AND OPEN LEG - ACCESSORIES



(A)	14" HIGH UNIT	FOR 4' BENCH	FOR 5' BENCH	FOR 6' BENCH
	WITH 1 SHELF	454T48	454T60	454T72
(B)	24" HIGH UNIT	FOR 4' BENCH	FOR 5' BENCH	FOR 6' BENCH
	WITH 1 SHELF	451T48	451T60	451T72
	WITH 2 SHELVES	452T48	452T60	452T72
	WITH 3 SHELVES	453T48	453T60	453T72
(D)	36" HIGH UNIT	FOR 4' BENCH	FOR 5' BENCH	FOR 6' BENCH
	WITH 1 SHELF	461T48	461T60	461T72
	WITH 2 SHELVES	462T48	462T60	462T72
	WITH 3 SHELVES	463T48	463T60	463T72
	EXTRA SHELVES	450T48	450T60	450T72
(C)	CABINET	13" D x 36" W x 27" H CAT. No. 1735		

NOTE: TO ORDER PRODUCTION BOOSTER WITH TOP SHELF THAT CAN BE TILTED, SUBSTITUTE "-" FOR "T" IN PART NUMBER.
INTERMEDIATE SHELVES ARE 13 1/2" DEEP X 44", 56" OR 68" LONG.
FULL LENGTH TOP SHELVES ARE 13 1/2" DEEP X 48", 60" OR 72" LONG.

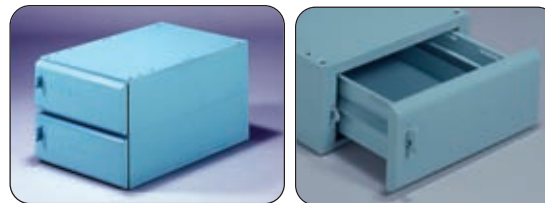

DRAWERS

PILFER-PROOF, ENCLOSED FRAME, IN 2 WIDTHS AND HEIGHTS, FOR MOUNTING UP TO 3 WIDE AND 3 HIGH WITH HASP AND KNOCKOUT FOR LOCKS.

DRAWERS

DRAWER SIZE	FOR BENCH TOP TYPE	STARTING UNIT	ADDITIONAL UNIT	2-DRAWER STACK	3-DRAWER STACK
REGULAR SIZE	STEEL OR HARDBOARD	221	221A	221-2	221-3
OVERALL UNIT DIMENSIONS	6 1/4"H x 15"W x 23 3/4"L ON STEEL				
REGULAR SIZE	WOOD, LAMINATE, OR ESD (ANTI-STATIC)	221A	221A	221A2	221A3
OVERALL UNIT DIMENSIONS	6 1/4"H x 15"W x 23 3/4"L (ANTI-STATIC)				
EXTRA LARGE	STEEL OR HARDBOARD	223	223A	223-2	223-3*
OVERALL UNIT DIMENSIONS	7 3/4"H x 21 1/2"W x 23 3/4"L ON STEEL				
EXTRA LARGE	WOOD, LAMINATE, OR ESD (ANTI-STATIC)	223A	223A	223A2	223A3*
OVERALL UNIT DIMENSIONS	7 3/4"H x 21 1/2"W x 23 3/4"L (ANTI-STATIC)				

*NOTE: FITS ONLY BENCHES WITHOUT BOTTOM SHELVES

(E) 14" HIGH x 12" DEEP

5'	226-60	30"	226-30
4'	226-48	6'	226-72

NOTE: WILL NOT FIT 36" DEEP STEEL TOPS.

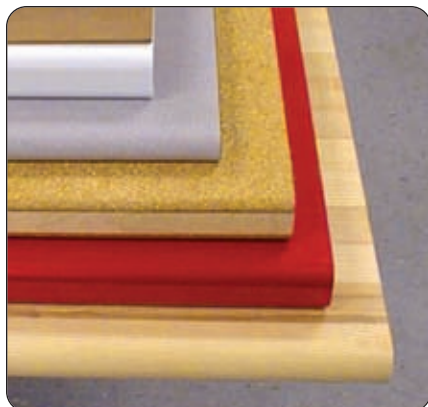

BACK RAIL — WOOD TOP

DESCRIPTION	CATALOG No.
4' LONG	7404
5' LONG	7405
6' LONG	7406
8' LONG	7411
30" LONG	7407

END RAIL — WOOD TOP

DESCRIPTION	CATALOG No.
30" LEFT	7420L
30" RIGHT	7420R
36" LEFT	7421L
36" RIGHT	7421R

END RAIL — STEEL TOP

DESCRIPTION	CATALOG No.
30" LEFT	7417L
30" RIGHT	7417R
36" LEFT	7418L
36" RIGHT	7418R

TOPS STYLE	LENGTH	30"	36"
		DEEP	DEEP
STEEL TOP	4'	441U4	442U4
(12 GAUGE)	5'	441U5	442U5
WITH	6'	441U6	442U6
BACKSTOP	8'	441U8	442U8
STEEL TOP	4'	441D4	442D4
(12 GAUGE)	5'	441D5	442D5
WITHOUT	6'	441D6	442D6
BACKSTOP	8'	441D8	442D8
HARDBOARD	4'	441U4M	442U4M
ON STEEL,	5'	441U5M	442U5M
WITH	6'	441U6M	442U6M
BACKSTOP	8'	441U8M	442U8M
HARDBOARD	4'	441D4M	442D4M
ON STEEL,	5'	441D5M	442D5M
WITHOUT	6'	441D6M	442D6M
BACKSTOP	8'	441D8M	442D8M
BONDED	4'	441-4B	442-4B
WOOD,	5'	441-5B	442-5B
1 ³ / ₄ " THICK	6'	441-6B	442-6B
	8'	441-8B	442-8B
	4'	441-4W	442-4W
HARDWOOD	5'	441-5W	442-5W
1 ³ / ₄ " THICK	6'	441-6W	442-6W
	8'	441-8W	442-8W
ESD	4'	441-4C	442-4C
(ANTI-STATIC)	5'	441-5C	442-5C
1 ¹ / ₄ " THICK	6'	441-6C	442-6C
	8'	441-8C	442-8C
LAMINATED	4'	441-4P	442-4P
PLASTIC,	5'	441-5P	442-5P
1 ¹ / ₄ " THICK	6'	441-6P	442-6P
	8'	441-8P	442-8P



121212

CONVENIENCE CUBE

12" x 12" x 12" CUBE. PROTECT FRAGILE ITEMS OR PERSONALIZE A WORKCENTER. LOCK DOOR WITH PAD-LOCK OR KEY LOCK.



LOCKS

LOCK ASSEMBLY FITS ALL BENCH DRAWERS AND DOORS (PADLOCK HASP IS STANDARD).

DESCRIPTION	CATALOG No.
KEY LOCK	10405

NUMBER PLATES

AVAILABLE FOR ANY NUMBER FROM 1 - 500 (PLEASE SPECIFY).
NUMBER PLATE 13013



229-4

ELECTRICAL POWER CENTER

COMPACT, WITH 4 OUTLETS, ON -OFF SWITCH, 15 AMP BREAKER, 15 FT. CORD WITH GROUND. EASY TO INSTALL WHERE YOU NEED IT.

CLOSED LEG AND PEDESTAL WORKCENTER - ACCESSORIES ONLY

PEDESTAL FOR BENCHES

DESCRIPTION	CATALOG No.
DOOR PEDESTAL (NO TOP)	233LT
4-DRAWER PEDESTAL (NO TOP)	237LT
LEGS FOR BENCHES	
LEFT HAND CLOSED LEG PANEL	230L
RIGHT HAND CLOSED LEG PANEL	230R

BENCH SHELVES

BENCH SERIES No.	BENCH LENGTH	SHELF DEPTH	CATALOG NUMBER
210 & 215 SERIES	4'	11 ¹ / ₂ "	6322
	5'	11 ¹ / ₂ "	6323
	6'	11 ¹ / ₂ "	6312
	8'	11 ¹ / ₂ "	6312
240 & 245 SERIES	4'	11 ¹ / ₂ "	6330
	5'	11 ¹ / ₂ "	6334
	6'	11 ¹ / ₂ "	6313
	8'	11 ¹ / ₂ "	6313
250 SERIES	4'	11 ¹ / ₂ "	6332
255 SERIES	5'	11 ¹ / ₂ "	6336
260 SERIES	6'	11 ¹ / ₂ "	6314
	8'	11 ¹ / ₂ "	6314
265 & 270 SERIES	4'	19 ³ / ₄ "	6327A
275 & 280 SERIES	5'	19 ³ / ₄ "	6328A
(INTERMEDIATE SHELVES)	6'	19 ³ / ₄ "	6329A
	8'	19 ³ / ₄ "	6329A
265 & 270 SERIES	4'	20 ¹ / ₄ "	6315
275 & 280 SERIES	5'	20 ¹ / ₄ "	6316
(BOTTOM SHELVES)	6'	20 ¹ / ₄ "	6317
	8'	20 ¹ / ₄ "	6317

IRON-I WORKCENTER - ACCESSORIES



EQUIPTO IRON-I BENCHES HAVE THE FLEXIBILITY FOR PLANNED EXPANSION. OUR PARTS AND ACCESSORIES ALLOW YOU TO KEEP UP WITH CHANGING REQUIREMENTS.

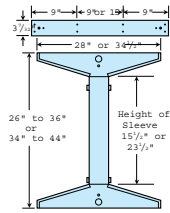

IRON-I

THE IRON-I'S LEGS ADJUST FROM HEIGHTS OF 26" TO 44" IN 1/2" INCREMENTS. ALL STRUCTURAL PARTS ARE 12 GAUGE (.104") STEEL. EACH LEG WILL SUPPORT 1,000 LBS.

BENCH LEGS		
DEPTH	HEIGHT	CATALOG NO.
29"	26"-36"	420L30
35"	26"-36"	420L36
29"	34"-44"	420H30
35"	34"-44"	420H36

BENCH BASE	
LENGTH	CATALOG No.
4'	6844
5'	6845
6'	6846

CASTER SET	
QUANTITY	CATALOG No.
4	11649-04

LEVELLER SET	
QUANTITY	CATALOG No.
4	11650-04

BOTTOM SHELVES	
DESCRIPTION	CATALOG No.
13 1/2"x4'	6054
13 1/2"x5'	6055
13 1/2"x6'	6056
13 1/2"x8'	6056

OPEN LEG WORKCENTERS - ACCESSORIES

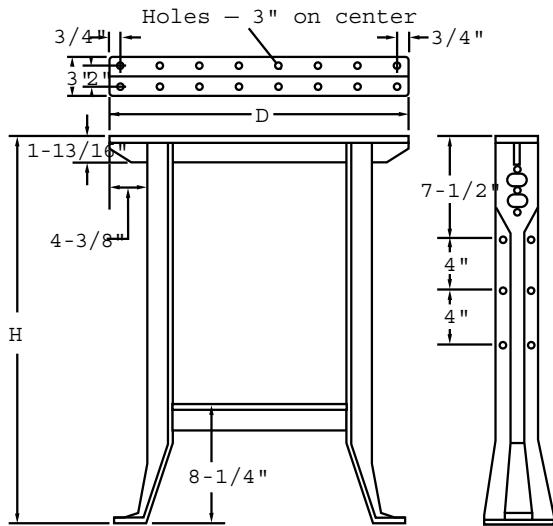

BENCH LEGS			
WELDED, ONE-PIECE STEEL UNITS SEAMED FOR STRENGTH AND SAFETY.			
DEPTH	HEIGHT(H)	WEIGHT	CATALOG No.
NOMINAL 30"			
28 1/2"	29"	14 LBS.	9921
28 1/2"	31 1/4"	15	9922
28 1/2"	34"	16	9923
NOMINAL 36"			
34 1/2"	29"	15	9931
34 1/2"	31 1/4"	16	9932
34 1/2"	34"	17	9933

BACK STRINGERS		
SIZE	WEIGHT	CATALOG No.
4'	6 LBS.	10251
5'	7	10252
6'	8	10253

BOTTOM SHELVES		
SIZE	WEIGHT	CATALOG No.
12 7/8" x 4'	16 LBS.	6120
12 7/8" x 5'	19	6121
12 7/8" x 6'	25	6122

MOBILE CASTER KIT FOR BENCH	
MOBILE KIT ADDS 7 1/2" TO THE HEIGHT OF BENCH	
DEPTH	CATALOG No.
30"	2203
36"	2204

CASTER KITS INCLUDE: (4) CASTERS



STANDARD COLOR - OFFICE GRAY. COLOR COORDINATING? REFER TO EQUIPTO COLOR CHART - INSIDE REAR COVER.