

51110ASY

---

**EQUIPTO**

---

Closed Work Bench  
Assembly Instructions

**READ INSTRUCTIONS BEFORE ASSEMBLING**

# CLOSED – LEG BENCH ASSEMBLY INSTRUCTIONS

## A. CLOSED LEG AND CABINET BENCH COMBINATIONS

## B. ASSEMBLY PROCEDURE:

1. ASSEMBLE BACK STRINGER AS SHOWN IN STEP 1. DO NOT TIGHTEN THE BOLTS UNTIL THE WORKBENCH IS COMPLETELY ASSEMBLED.
2. ASSEMBLE HALF SHELF AS SHOWN IN STEP 2. DO NOT TIGHTEN THE BOLTS UNTIL THE WORKBENCH IS COMPLETELY ASSEMBLED.
3. FASTEN STEEL BENCH TOP IN PLACE AS SHOWN IN STEP 3. TIGHTEN ALL FASTENERS SECURELY.
4. INSTALL FILLERS FOR 96” STEEL TOP AS SHOWN IN STEP 4.
5. ASSEMBLE WOOD TOP ON BENCH AS SHOWN IN STEP 5. TIGHTEN ALL FASTENERS SECURELY.
6. ADDITIONAL NOTES FOR INSTALLING HARDBOARD ON STEEL PLUGS, DRAWER STOPS AND DRAWER LINERS.

## C. LIST OF BENCH TOP MATERIALS AVAILABLE

1. MATERIALS FOR STEEL TOP.
2. MATERIALS FOR WOOD TOP.



# CLOSED LEG AND CABINET BENCH COMBINATIONS

210 SERIES &  
215 SERIES

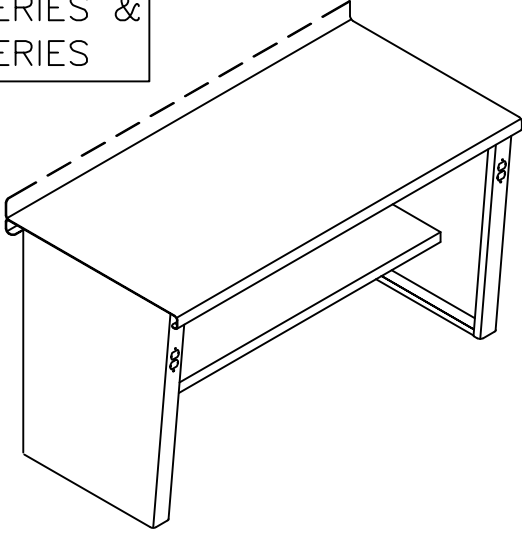

240 SERIES

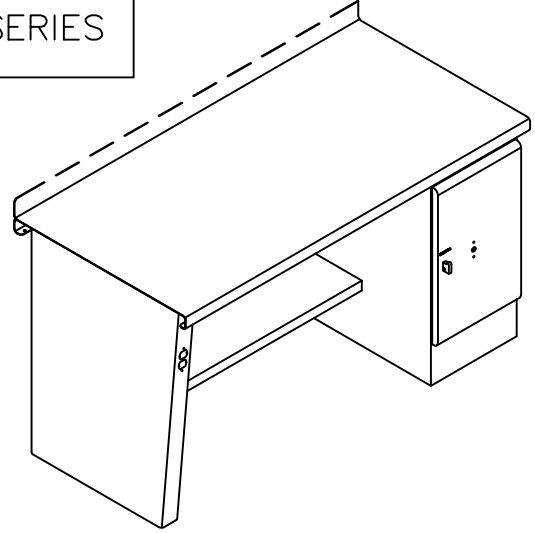

245 SERIES

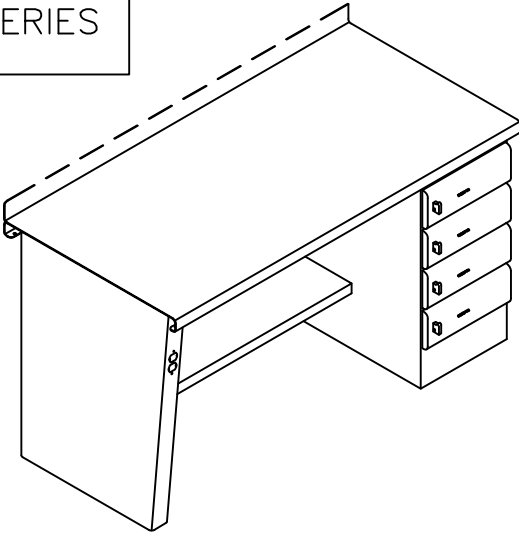

250 SERIES

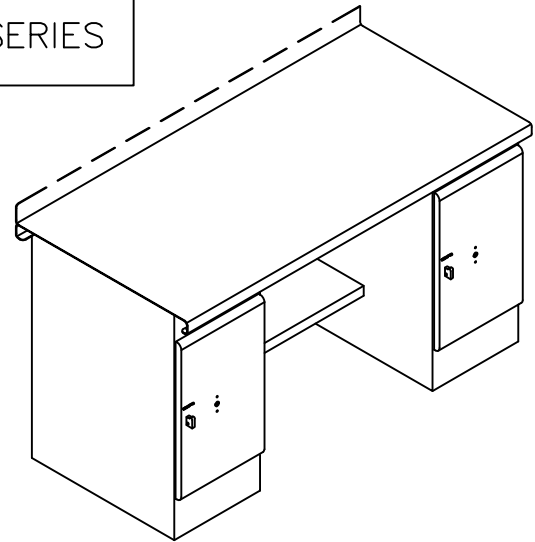

255 SERIES

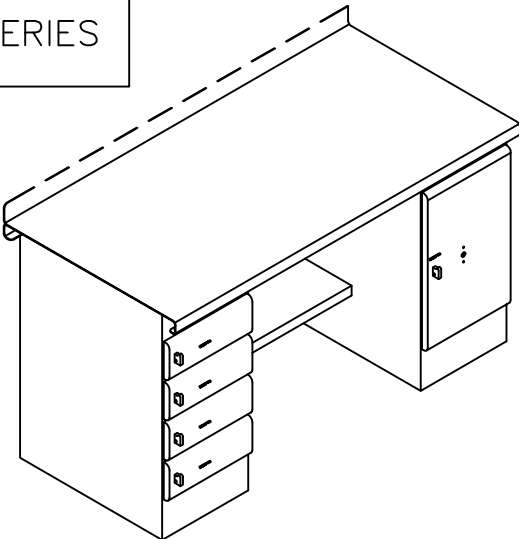

260 SERIES

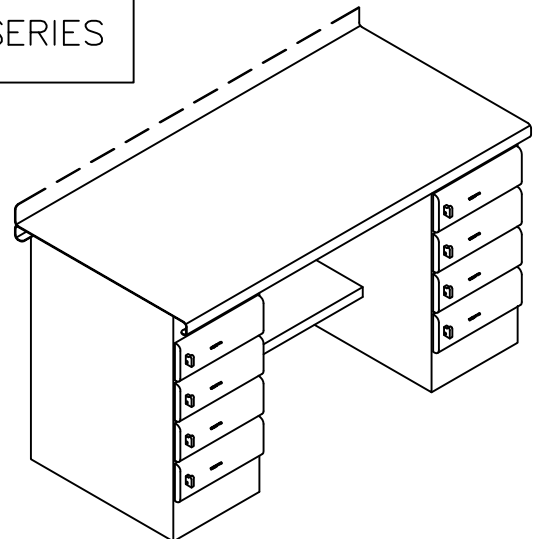

# B ASSEMBLY PROCEDURE

## Step

### 1 BACK STRINGER ASSEMBLY

#### FOR #210 AND 215 SERIES ONLY

#### NOTE

DO NOT TIGHTEN THE BOLTS UNTIL THE WORKBENCH IS COMPLETELY ASSEMBLED.

#### NOTE

USE INSIDE HOLES IN STRINGER.

#7890  
CLOSED LEG-LH

7889  
CLOSED LEG-RH

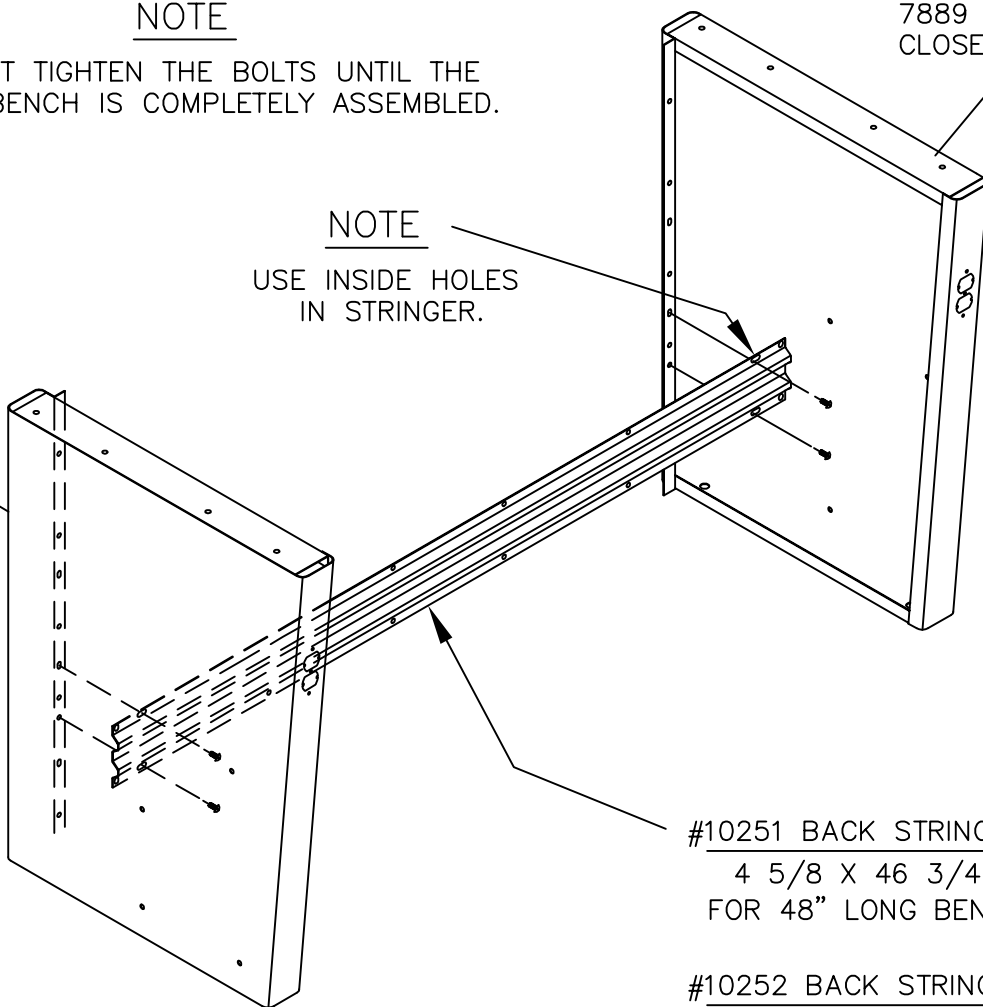

#10251 BACK STRINGER

4 5/8 X 46 3/4"  
FOR 48" LONG BENCH

#10252 BACK STRINGER

4 5/8 X 58 3/4"  
FOR 60" LONG BENCH

#10253 BACK STRINGER

4 5/8 X 70 3/4"  
FOR 72" AND 96" LONG BENCH

#13154 TRUSS HD MACH SCREW

5/16" X 3/4"

#13051 TWIN WHIZZ LOCKNUT

5/16" - 18

(4 PER STRINGER)

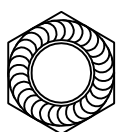
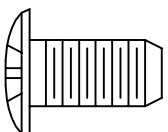

FULL SCALE

PATENT PENDING

# Step

## 2

# HALF SHELF ASSEMBLY

### NOTE

DO NOT TIGHTEN THE BOLTS UNTIL THE WORKBENCH IS COMPLETELY ASSEMBLED.

### NOTE

COMMON SCREWS FOR BOTH HALF SHELF AND STRINGER.(2)

215 SERIES

#6322 HALF SHELF

11 1/2" X 47 29/32"  
FOR 48" LONG BENCH

#6323 HALF SHELF

11 1/2" X 59 29/32"  
FOR 60" LONG BENCH

#6312 HALF SHELF

11 1/2" X 71 29/32"  
FOR 72" AND 96" LONG BENCH

#6330 HALF SHELF

12" X 32 13/16"  
FOR 48" LONG BENCH

#6334 HALF SHELF

12" X 44 15/16"  
FOR 60" LONG BENCH

240 SERIES

245 SERIES

#6313 HALF SHELF

12" X 56 15/16"  
FOR 72" AND 96" LONG BENCH

233LT  
DOOR  
PEDESTAL

237LT  
DRAWER  
PEDESTAL

250 SERIES

255 SERIES

260 SERIES

#6332 HALF SHELF

12" X 18"  
FOR 48" LONG BENCH

#6336 HALF SHELF

12" X 30"  
FOR 60" LONG BENCH

#6314 HALF SHELF

12" X 42"  
FOR 72" AND 96" LONG BENCH

### NOTE

TO GAIN ACCESS TO THE MOUNTING HOLES IN THE DRAWER PEDESTAL, REMOVE THE TWO TOP DRAWERS.

#13154 TRUSS HD MACH SCREW  
5/16" X 3/4"

#13051 TWIN WHIZZ LOCKNUT  
5/16" - 18

(2 PER HALF SHELF FOR 215 SERIES)

(6 PER HALF SHELF FOR 240, 245,  
250, 255 AND 260 SERIES)

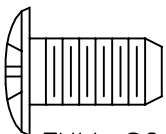

FULL SCALE

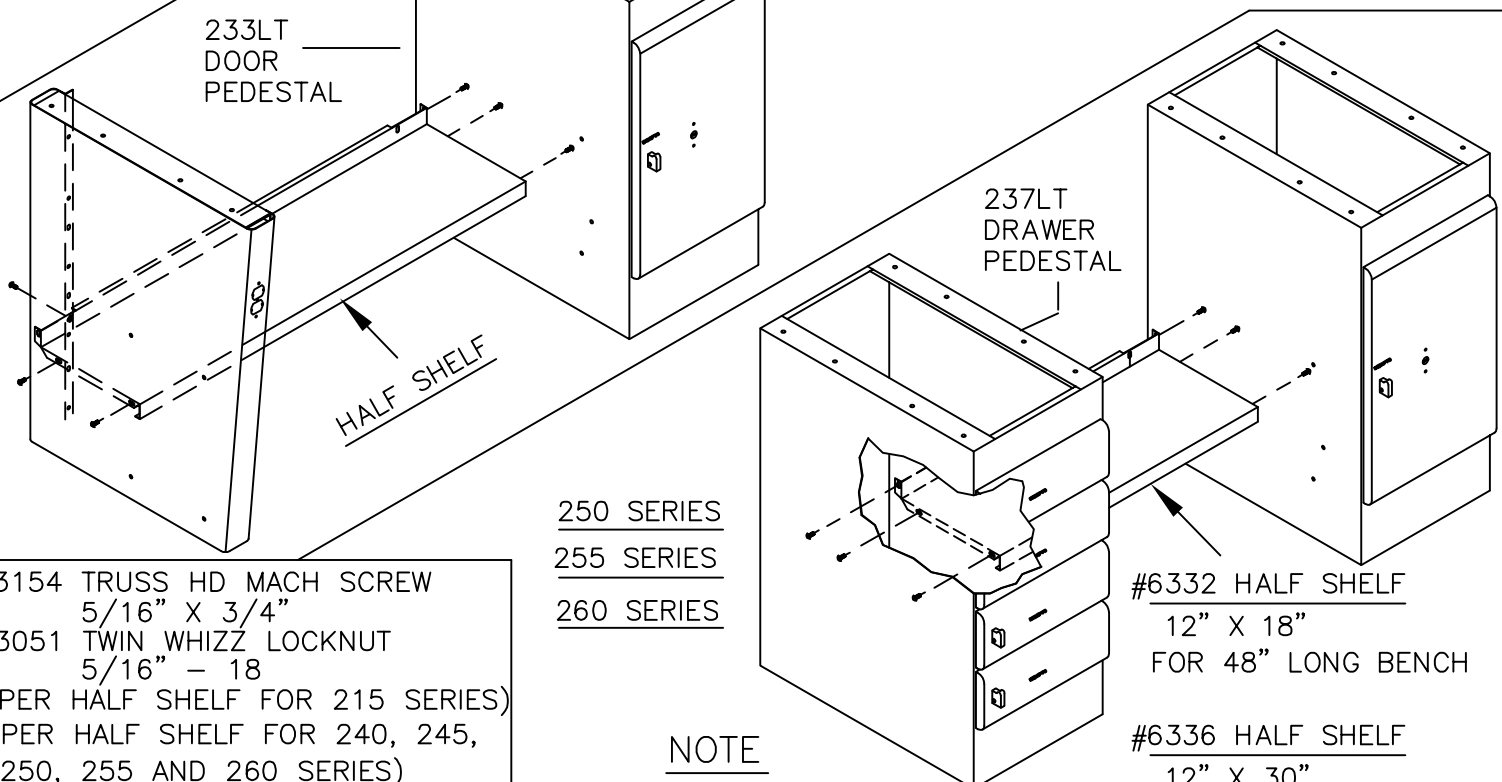
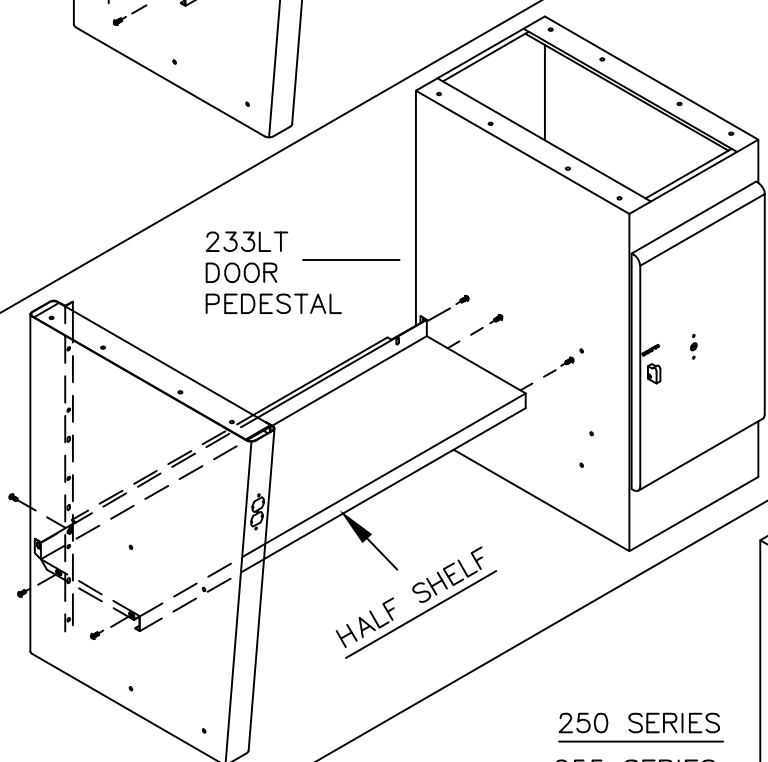
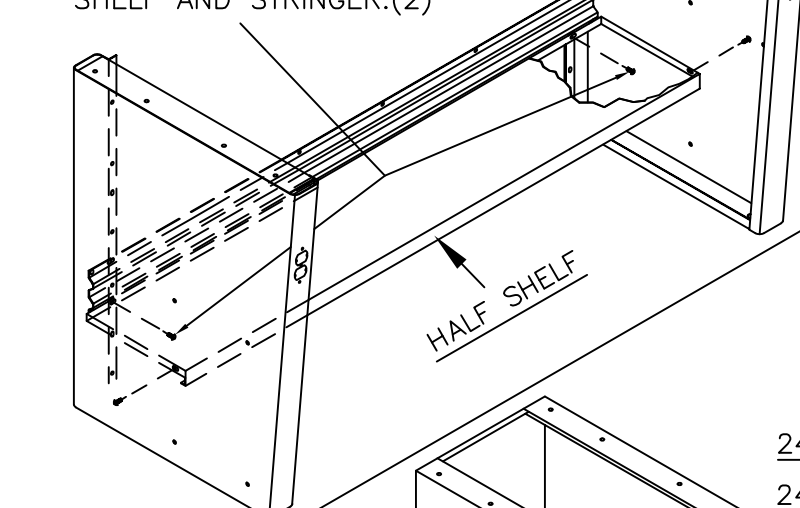
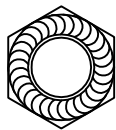

# Step

# 3

## STEEL TOP ASSEMBLY

(SAME FOR ALL COMBINATIONS)

### NOTE

OPTIONAL END RAILS AND AERIAL SHELF MUST BE ATTACHED AT THIS POINT. IF YOU HAVE AN AERIAL SHELF SEE THOSE INSTALLATION INSTRUCTIONS.

### END RAILS (16 GA.)

LEFT HAND	SIZE	RIGHT HAND
#7417L	30" STEEL	#7417R
#7418L	36" STEEL	#7418R

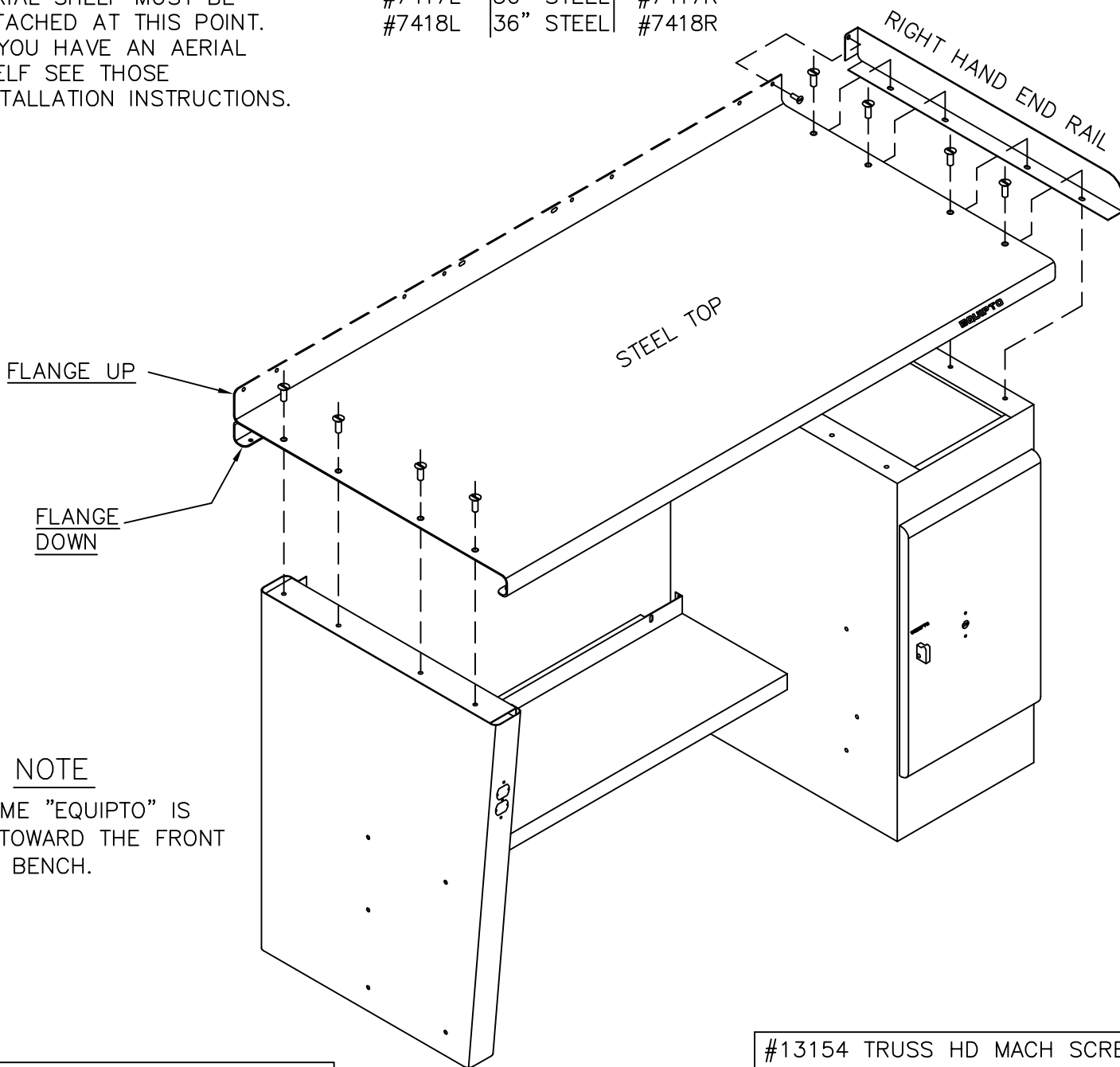

### NOTE

THE NAME "EQUIPTO" IS TO BE TOWARD THE FRONT OF THE BENCH.

#13165 FLAT HEAD BOLT 1/4" x 1"

#13060 KEPS NUT 1/4"

(8 PER TOP)

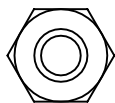
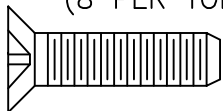

FULL SCALE

#13154 TRUSS HD MACH SCREW  
5/16" X 3/4"

#13051 TWIN WHIZZ LOCKNUT  
5/16" - 18

(1 PER END RAIL)

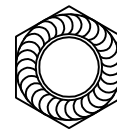
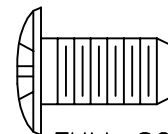

FULL SCALE

# Step

4

## FILLER INSTALLATION FOR 96" STEEL TOPS ONLY

FILLER (14 GA.)

FLANGE DOWN	SIZE	FLANGE UP
#7735	30"	#7737
#7736	36"	#7738

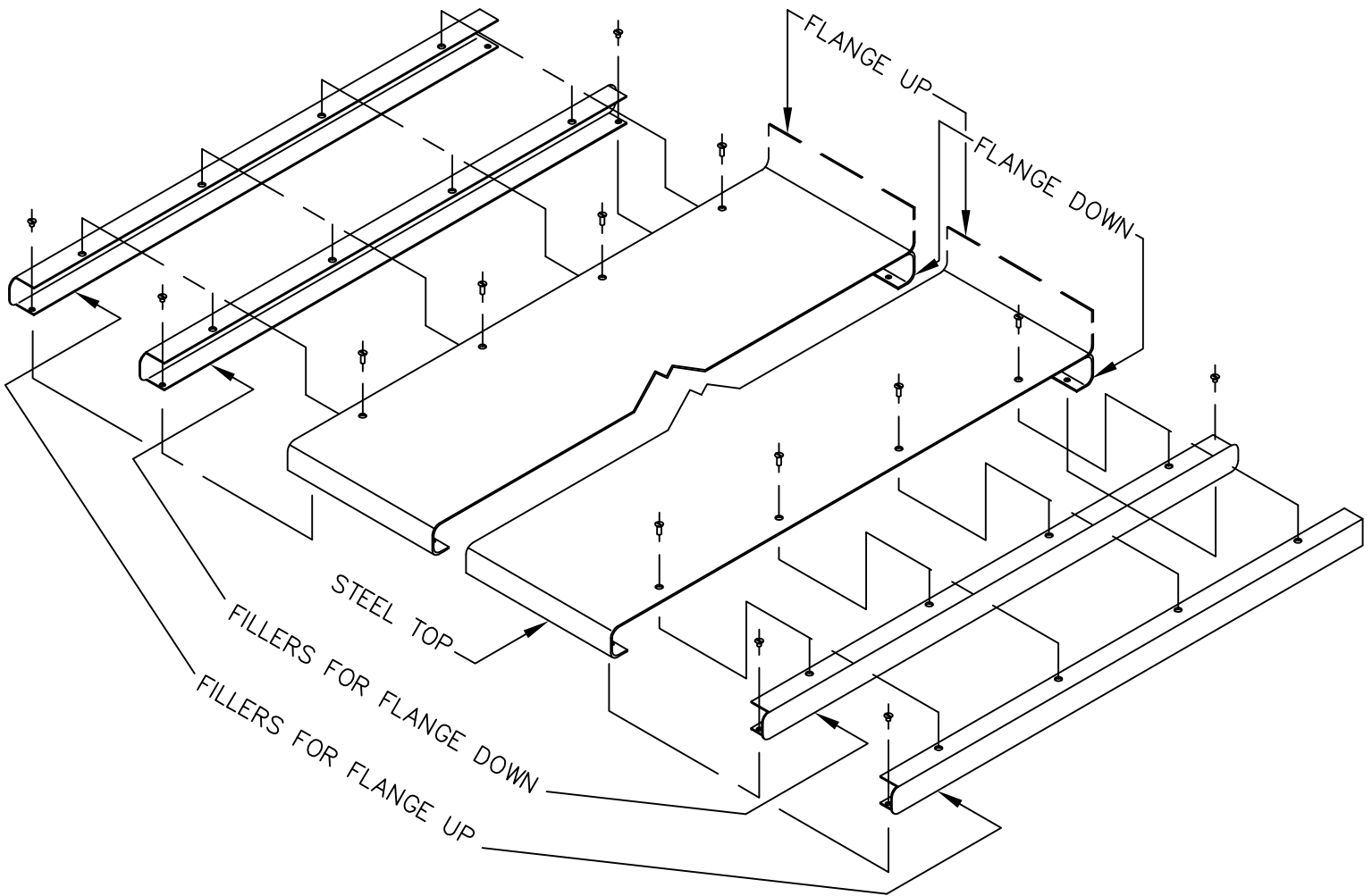

#13165 FLAT HEAD BOLT 1/4" x 1"

#13060 KEPS NUT 1/4"

(8 PER TOP)

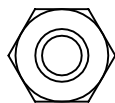
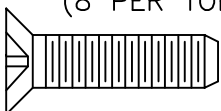

FULL SCALE

#13162 TRUSS HD MACH SCREW 1/4" X 1/2"

#13060 KEPS NUT 1/4"

(2 PER FILLER FOR FLANGE DOWN)

(1 PER FILLER FOR FLANGE UP)

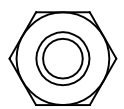
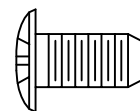

FULL SCALE

# Step

# 5

## WOOD TOP ASSEMBLY

(SAME FOR ALL COMBINATIONS)

### NOTE

OPTIONAL END AND BACK RAILS MUST BE ATTACHED AT THIS POINT.

### NOTE

AFTER THE BACK RAIL IS IN POSITION AND FASTENED TO THE REAR FLANGES OF THE END RAILS, DRILL 3/16" DIA. X 1" DEEP PILOT HOLES IN THE REAR EDGE OF THE WOOD TOP.

### END RAILS (16 GA.)

LEFT HAND	SIZE	RIGHT HAND
#7420L	30" WOOD	#7420R
#7421L	36" WOOD	#7421R

### BACK RAILS

- #7404 - 48"
- #7405 - 60"
- #7406 - 72"
- #7411 - 96"

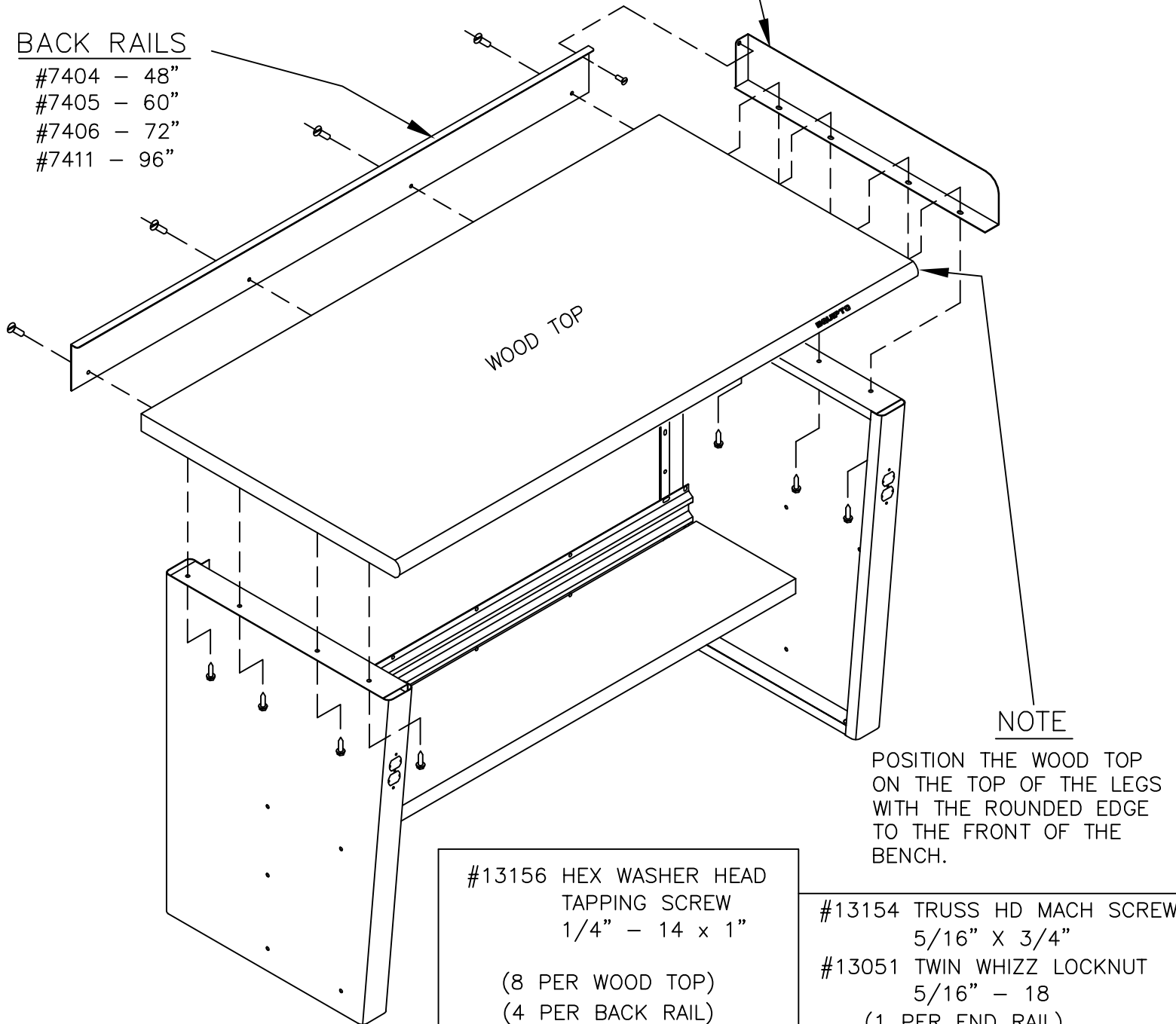

### NOTE

POSITION THE WOOD TOP ON THE TOP OF THE LEGS WITH THE ROUNDED EDGE TO THE FRONT OF THE BENCH.

#13156 HEX WASHER HEAD TAPPING SCREW  
1/4" - 14 x 1"

(8 PER WOOD TOP)  
(4 PER BACK RAIL)

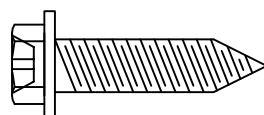

FULL SCALE

#13154 TRUSS HD MACH SCREW  
5/16" X 3/4"

#13051 TWIN WHIZZ LOCKNUT  
5/16" - 18

(1 PER END RAIL)

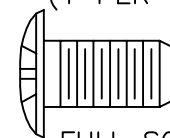

FULL SCALE





# 6

## ADDITIONAL NOTES

a. FOR HARDBOARD ON STEEL, AFTER TOP IS ATTACHED INSERT PLUGS AS SHOWN.

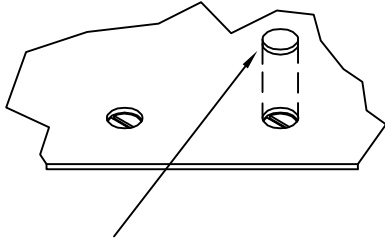

#10206-3/4" DIA. PLUG

b. FOR DRAWER PEDESTALS INSTALL DRAWER STOPS AND LINERS FOR EACH DRAWER AS SHOWN.

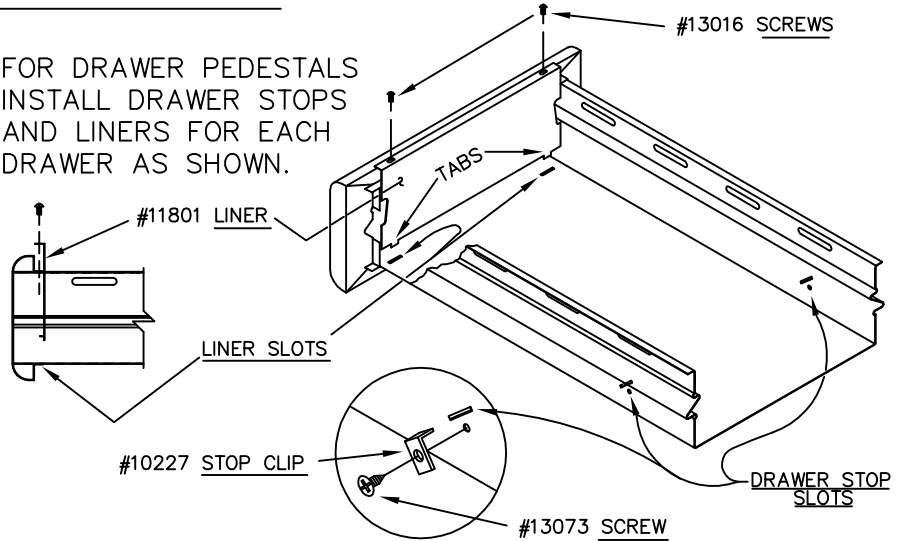

SEE ADDITIONAL ACCESSORY INSTRUCTIONS:

- #37ASY - WORKBENCH DRAWERS
- #75ASY - AERIAL SHELF & PICK RACK KITS
- #81ASY - PRODUCTION BOOSTER AERIAL SHELF

#13073 PAN HD TYPE A SHT. MTL. SCREW  
1/4" X 3/8"  
(2 PER DRAWER)



FULL SCALE

#13016 PHILLIPS PAN HD. SHT. MTL. SCREW  
#8 X 3/8"  
(2 PER DRAWER)

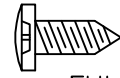

FULL SCALE

# C

## BENCH TOP MATERIALS AVAILABLE

### 1

### MATERIALS FOR STEEL TOP

STEEL (12 GA.)

HARDBOARD ON STEEL (12 GA.)

FLANGE DOWN	SIZE	FLANGE UP
#11479D	30" x 48"	#11479
#11480D	30" x 60"	#11480
#11481D	30" x 72"	#11481
#11482D	30" x 96"	#11482
#11463D	36" x 48"	#11463
#11464D	36" x 60"	#11464
#11465D	36" x 72"	#11465
#11370D	36" x 96"	#11370

FLANGE DOWN	SIZE	FLANGE UP
#441D4M	30" x 48"	#441U4M
#441D5M	30" x 60"	#441U5M
#441D6M	30" x 72"	#441U6M
#441D8M	30" x 96"	#441U8M
#442D4M	36" x 48"	#442U4M
#442D5M	36" x 60"	#442U5M
#442D6M	36" x 72"	#442U6M
#442D8M	36" x 96"	#442U8M

### 2

### MATERIALS FOR WOOD TOP

BONDED WOOD 1-3/4" THICK

CONDUCTIVE 1-1/4" THICK

LAMINATED MAPLE 1-3/4" THICK

#12312	30" x 48"	#12347	30" x 48"
#12305	30" x 60"	#12348	30" x 60"
#12306	30" x 72"	#12349	30" x 72"
#12380	30" x 96"	#12378	30" x 96"
#12314	36" x 48"	#12350	36" x 48"
#12315	36" x 60"	#12351	36" x 60"
#12316	36" x 72"	#12352	36" x 72"
#12381	36" x 96"	#12379	36" x 96"

#12338	30" x 48"
#12339	30" x 60"
#12340	30" x 72"
#12376	30" x 96"
#12341	36" x 48"
#12342	36" x 60"
#12343	36" x 72"
#12377	36" x 96"

51110ASY