

3668

---

EQUIPTO

---

IRON GRIP SHELVING  
ASSEMBLY INSTRUCTIONS

READ INSTRUCTIONS BEFORE ASSEMBLING

# ASSEMBLY INSTRUCTIONS FOR IRON-GRIP SHELVING

## ASSEMBLY PRECAUTION

BACK AND END SWAY BRACES MUST BE USED WITH OPEN TYPE SHELVING TO PROVIDE STABILITY. FAILURE TO ATTACH THE BRACES WILL RESULT IN AN UNSAFE UNIT.

NOTE: SEE HARDWARE LIST ON BACK

### OPEN SHELVING

- STEP 1. Install reinforcements and labelholders if required. Use #1 nut and #4 bolt.
- STEP 2. Lay two uprights(one R and one L) on sawhorses with the long flange up.
- STEP 3. Assemble front base (if provided) to the uprights using #3 bolt & #2 nut. (4 ea.).
- STEP 4. Install top, bottom and middle shelves by bolting them between the uprights using #3 bolt & #2 nut. (8 ea. per shelf). Then position and install rear (top) uprights on shelves using #3 bolt and #2 nut.
- STEP 5. Position and install other shelves and bin fronts as required. (4 #10392 per shelf). (See detail 11a and 11b for bin fronts)
- STEP 6. Position and install dividers using #10226 Plasti-drive rivets through slots in dividers and holes in shelves. When placing dividers in up and down alignment, insert rivet into upper divider, then shelf, then lower divider.
- STEP 7. Position and install reinforcements as shown in detail 7.
- STEP 8. Install end sway braces (see Brace detail #8a) & back sway braces using #3 bolt & #2 nut. (2 ea. per brace).
- STEP 9. Stand the unit upright and move into position.
- STEP 10. Fasten units in row with #10394 unit key if required.

### CLOSED SHELVING

- STEP 1. Install reinforcements and labelholders if required using #4 bolt and #1 nut. (see detail #7 and detail #9)
- STEP 2. Lay two uprights(one R and one L) on sawhorses with the long flange up.
- STEP 3. Install back panels. Bolt every 21" using #3 bolt & #2 nut.
- STEP 4. Install top, bottom and middle shelves by bolting them between the uprights using #3 bolt & #2 nut. (8 ea. per shelf)
- STEP 5. Position and install other shelves in unit. Position bin fronts if required using #4 bolt and #1 nut to bolt them to small holes in shelves.
- STEP 6. Position and install dividers using #10226 Plasti-drive rivets through slots in dividers and holes in shelves. When placing dividers in up and down alignment, insert rivet into upper divider, then shelf, then lower divider.
- STEP 7. Position and install front (top) uprights on shelves using #3 bolt and #2 nut. Position and install reinforcements as shown in detail 7.
- STEP 8. Install end panels.(see note) Bolt every 21" using #3 bolt & #2 nut.
- STEP 9. Assemble front base (if provided) to uprights using #3 bolt & #2 nut.
- STEP 10. Stand the unit upright and move into position. Fasten units in row with #10394 unit key if required.

THIS DRAWING IS THE PROPERTY OF

# EQUIPTO

Toll-Free Tel: 800-323-0801

Toll-Free Fax: 888-859-2121

www.equipto.com

©2003 BY EQUIPTO

REPRODUCTION STRICTLY FORBIDDEN

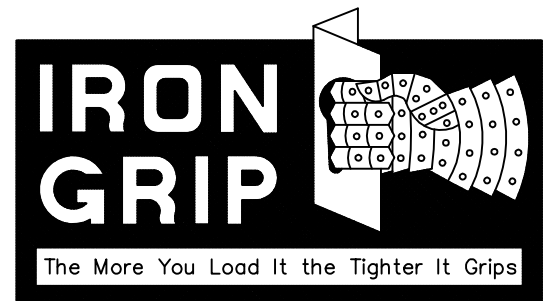

### HARDWARE LIST

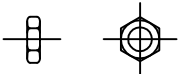
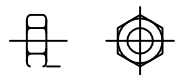
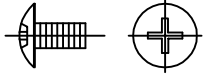
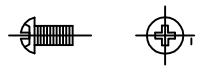
NUMBER	DESCRIPTION	HARDWARE
1	#13061 #10 KEPS NUT	
2	1/4" - #13060 20 KEPS NUT	
3	#13162 TRUSS HEAD SCREW 1/4" x 1/2"	
4	#13160 TRUSS HEAD SCREW #10-24 x 3/8"	

# ① OPEN SHELVING UNIT

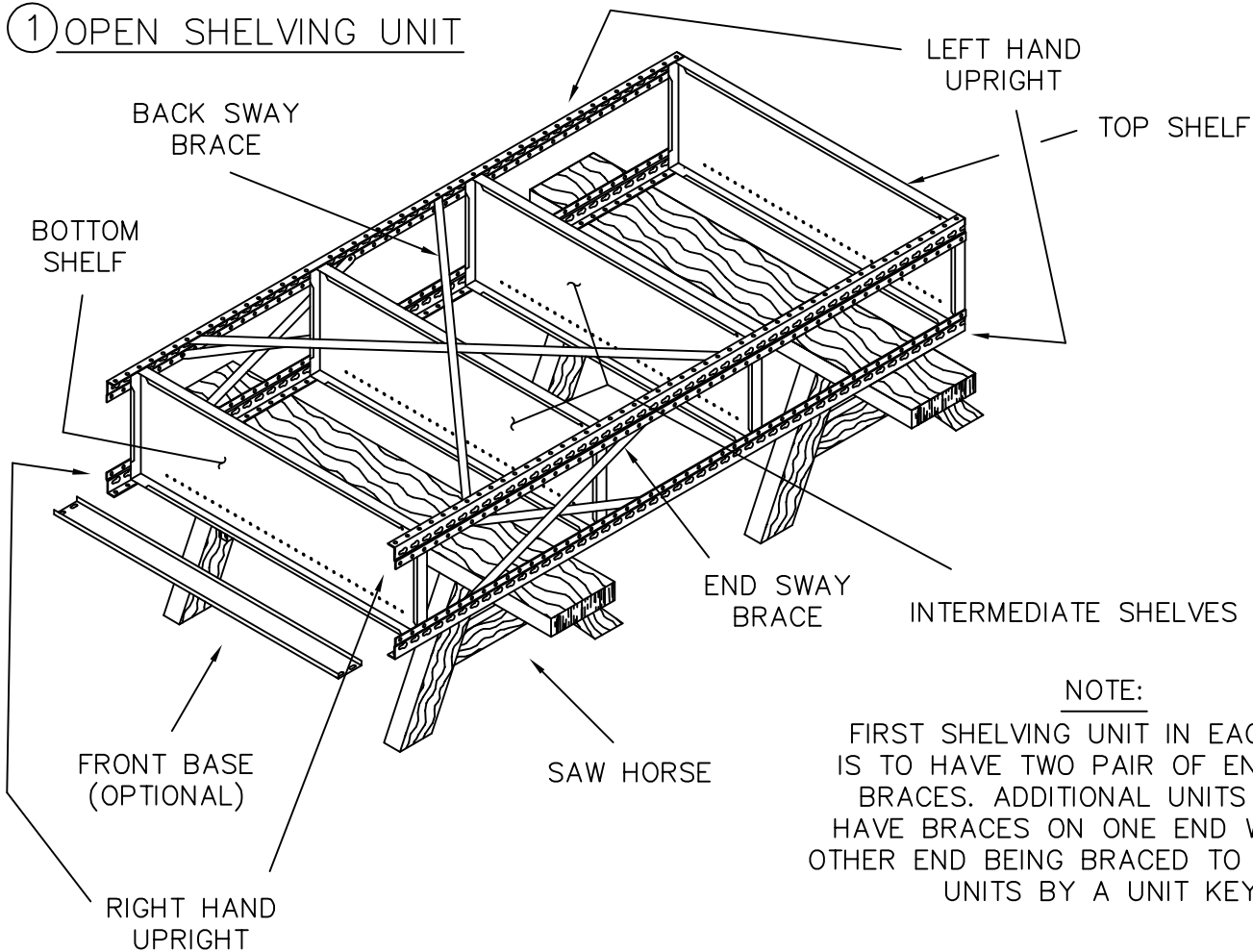

**NOTE:**  
FIRST SHELVING UNIT IN EACH ROW IS TO HAVE TWO PAIR OF END SWAY BRACES. ADDITIONAL UNITS SHALL HAVE BRACES ON ONE END WITH THE OTHER END BEING BRACED TO ADJACENT UNITS BY A UNIT KEY.

# ② CLOSED SHELVING UNIT

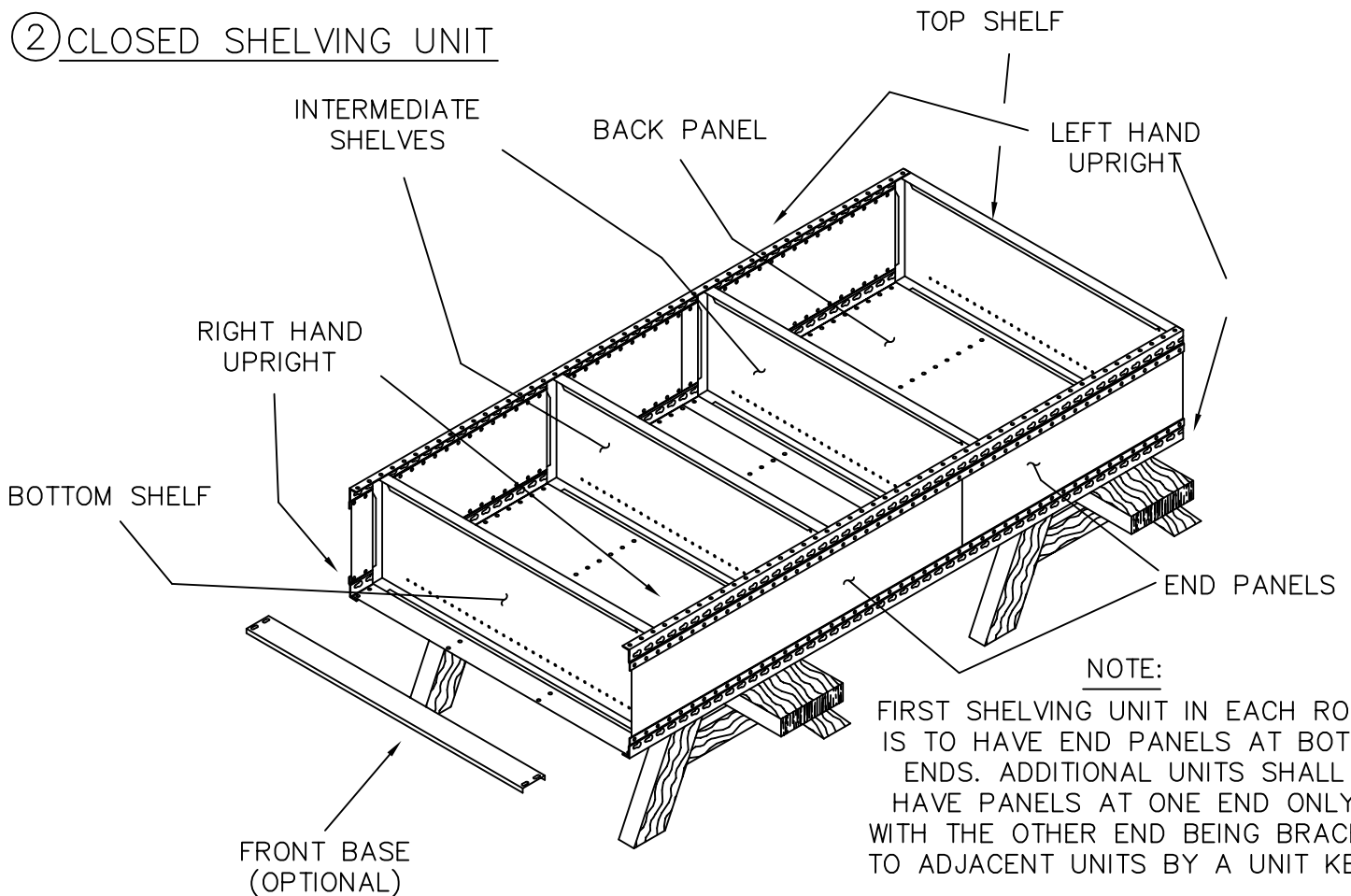

**NOTE:**  
FIRST SHELVING UNIT IN EACH ROW IS TO HAVE END PANELS AT BOTH ENDS. ADDITIONAL UNITS SHALL HAVE PANELS AT ONE END ONLY WITH THE OTHER END BEING BRACED TO ADJACENT UNITS BY A UNIT KEY.

### ③ BACK PANELS

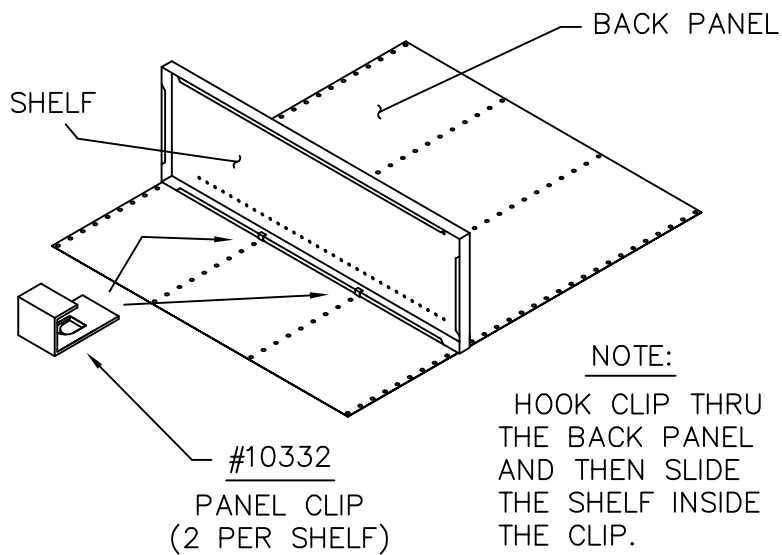

**NOTE:**

HOOK CLIP THRU THE BACK PANEL AND THEN SLIDE THE SHELF INSIDE THE CLIP.

### ④a TOP SHELF

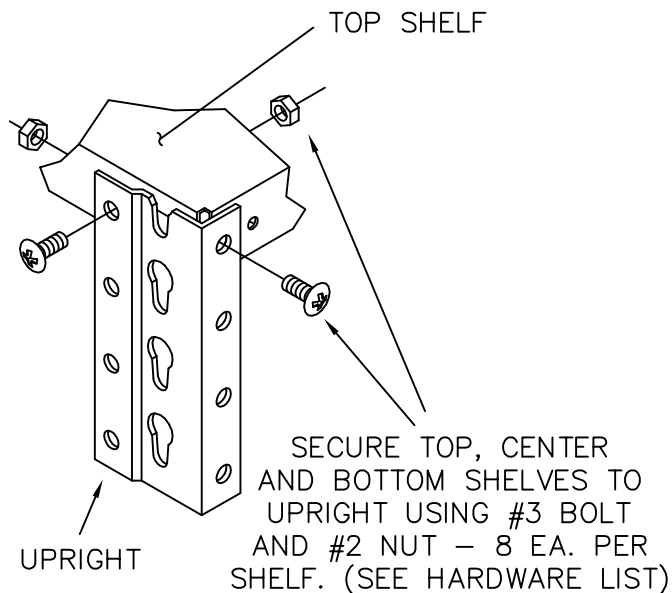

### ④b BOTTOM SHELF

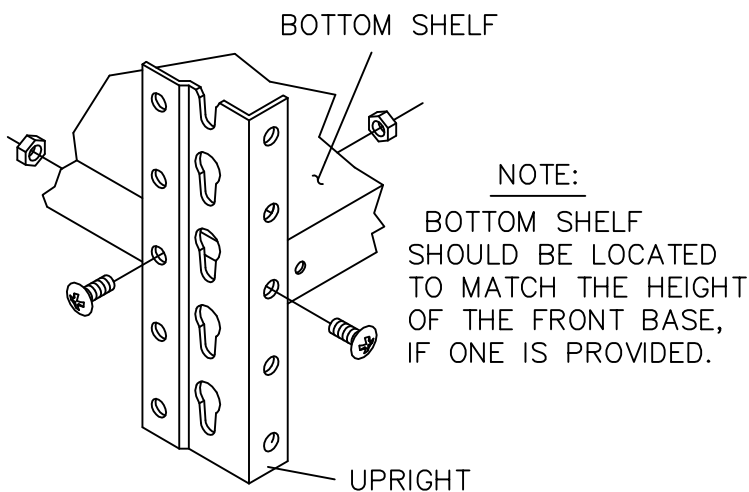

### ⑤ INTERMEDIATE SHELVES

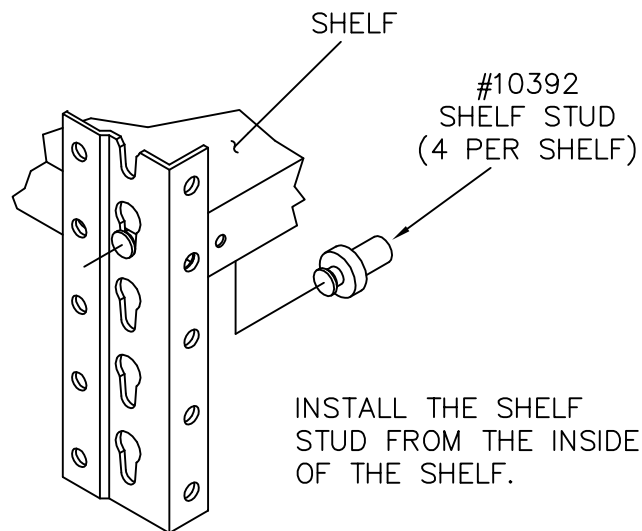

FOR UNITS WITH OPTIONAL BOLTING ON ALL SHELVES—SEE DETAIL 4b .

### ⑥ DIVIDERS

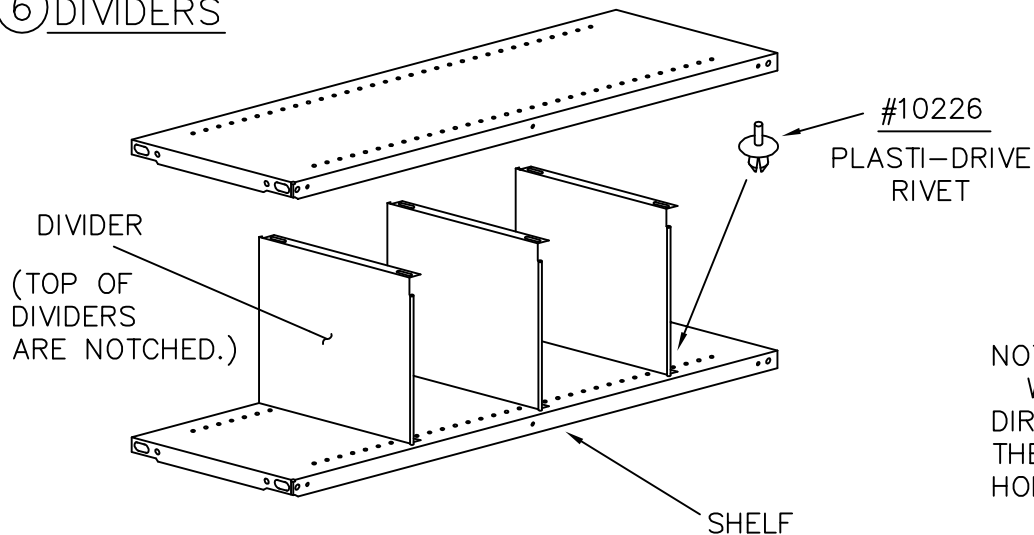

**NOTE:**

WHEN DIVIDERS ARE PLACED DIRECTLY ABOVE ONE ANOTHER, THE SAME PLASTI-DRIVE RIVETS HOLD BOTH DIVIDERS IN PLACE.

## ⑦ SHELF REINFORCEMENTS

SHELF  
(FRONT SECTION)

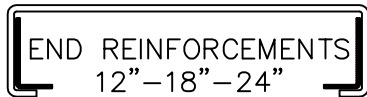

NOTE: IT IS NECESSARY TO INVERT END REINFORCEMENTS FOR 36" CENTER REINFORCEMENT

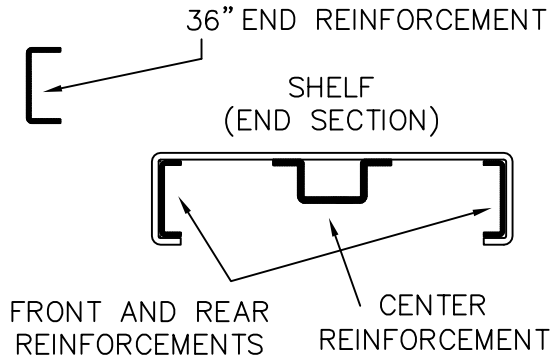

NOTE: TO INSTALL CENTER REINFORCEMENTS, TWIST INTO PLACE AS SHOWN.

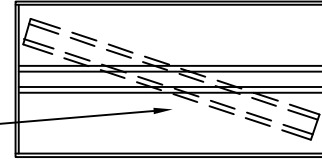

INSTALL THE SHELF REINFORCEMENTS (IF PROVIDED) BEFORE SHELVES ARE INSTALLED IN SHELVING UNIT.

STEP 1: BOLT IN FRONT AND REAR REINFORCEMENTS USING #4 BOLT AND #1 NUT.  
(3 EA. PER REINFORCEMENT)

STEP 2: BOLT IN END REINFORCEMENTS USING #4 BOLT AND #1 NUT.  
(3 EA. PER REINFORCEMENT)

STEP 3: TURN THE CENTER REINFORCEMENT INTO PLACE AS SHOWN. (NO HARDWARE REQUIRED)

## ⑧a SWAY BRACES

ATTACH END AND BACK SWAY BRACES TO UPRIGHTS USING #6 BOLT AND #2 NUT. (2 EA. PER SWAY BRACE)

UNIT	BRACE TYPE	PART NUMBER PAIR	A	B
36" WIDE	BACK	#6499	50"	36"
48" WIDE	BACK	#6431	66 7/8"	48"
12" DEEP	END	#6480	13 1/4"	10 1/2"
18" DEEP	END	#6481	25 1/4"	21"
24" DEEP	END	#6482	32"	25 1/2"
36" DEEP	END	#6483	48 1/4"	36"

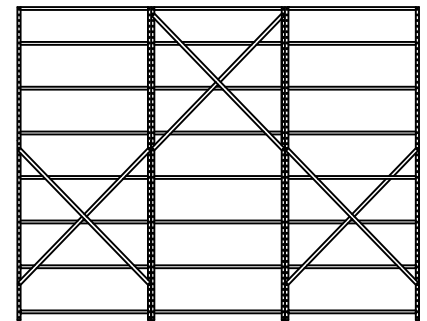
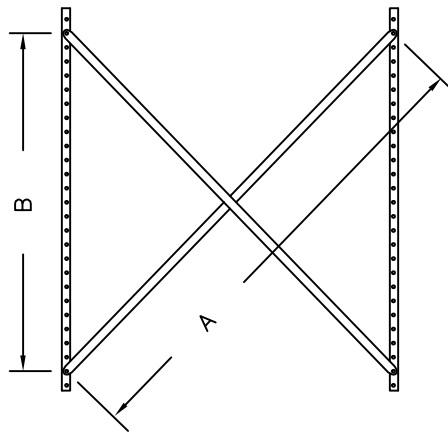

BACK SWAY BRACES ON SIDE BY SIDE UNITS.

## ⑧b ALTERNATE BRACING

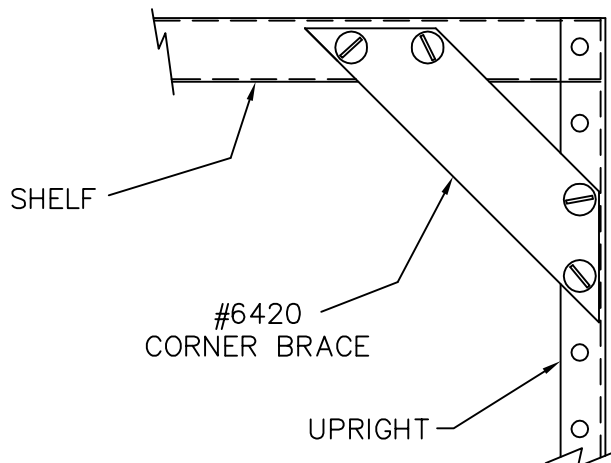

NOTE:

WHEN DESIRED, 12 #6420 CORNER BRACES PER UNIT MAY BE SUBSTITUTED FOR BACK SWAY BRACES. THESE SHOULD BE INSTALLED AT BOTH ENDS OF THE TOP, MIDDLE, AND BOTTOM SHELVES IN THE FRONT AND THE REAR OF THE UNIT. CUSTOMER MUST DRILL HOLES IN THE SHELF AS SHOWN TO INSTALL. USE #3 BOLT & #2 TO FASTEN BRACE TO UPRIGHT AND SHELF (4 ea. PER BRACE).

## ⑨ LABELHOLDERS

SEE DETAIL 10a AND 11 IF REINFORCEMENTS AND BIN FRONTS ARE REQUIRED.

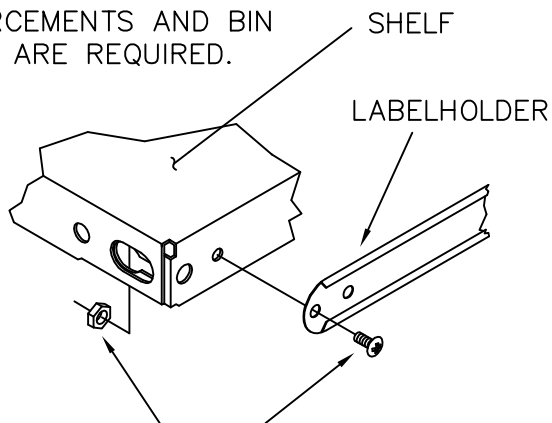

BOLT LABELHOLER TO FRONT OF SHELF USING #4 BOLT AND #1 NUT - 3 EA. PER LABELHOLDER. ATTACH PRIOR TO INSTALLING SHELF. (LABELHOLDER NOT REQUIRED FOR TOP SHELF.)

## ⑩ UNIT KEYS

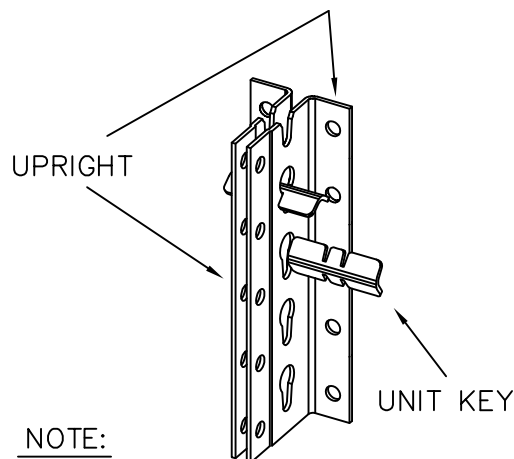

NOTE:  
INSERT THE UNIT KEY THROUGH THE KEYHOLES AND TURN. TAP DOWN TO TIGHTEN.

## ⑪a BIN FRONTS

SEE DETAIL 11 IF REINFORCEMENTS ARE REQUIRED.

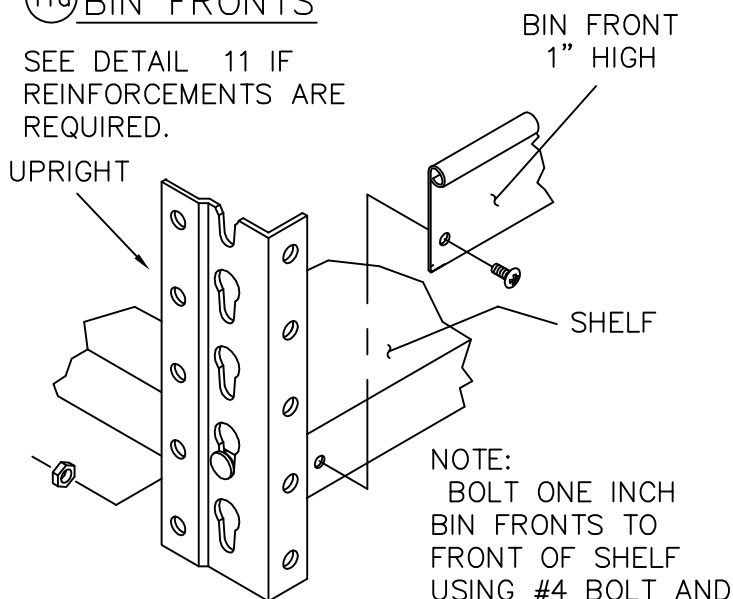

NOTE:  
BOLT ONE INCH BIN FRONTS TO FRONT OF SHELF USING #4 BOLT AND #1 NUT.(3 EA. PER BIN FRONT)

## ⑪b BIN FRONTS

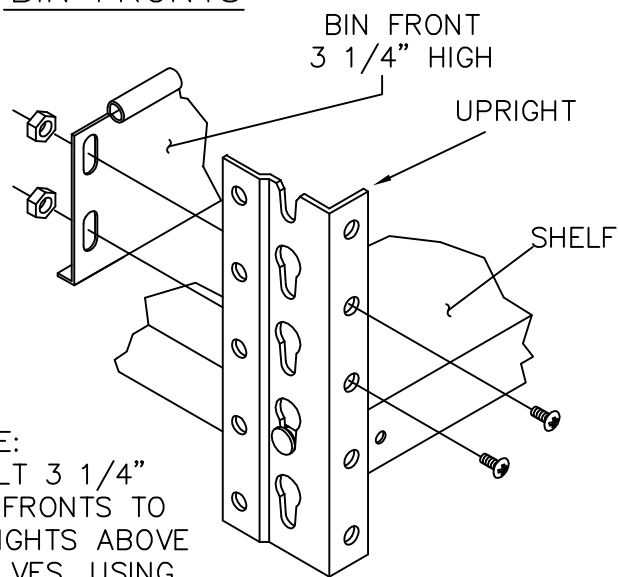

NOTE:  
BOLT 3 1/4" BIN FRONTS TO UPRIGHTS ABOVE SHELVES. USING #3 BOLT AND #2 NUT. (4 EA. PER BIN FRONT)

## IRON GRIP SHELVING PARTS LIST

SHELF DIVIDERS			
OPENNING	12" DEEP	18" DEEP	24" DEEP
3"	8018	8090	—
4 1/2 "	8019	8094	8119
6"	8020	8095	8120
7 1/2"	8021	8096	8121
9"	8022	8097	8122
10 1/2"	8023	8098	8123
12"	8024	8099	8124
13 1/2"	8025	—	8125
15"	8026	8091	8126
16 1/2"	—	8092	—

UPRIGHTS		
	LEFT	RIGHT
5' HIGH	5582L	5583R
6' HIGH	5586L	5587R
7' HIGH	5588L	5589R
8' HIGH	5590L	5591R
10' HIGH	5594L	5595R
36" HIGH	5598L	5599R
42" HIGH	5596L	5597R

END PANELS			
	42" HIGH	UpTo 84"H	UpTo 120"H
12"DEEP	7982	7982-2	7982-3
18"DEEP	7983	7983-2	7983-3
24"DEEP	7984	7984-2	7984-3
36"DEEP	7991	7991-2	7991-3

SHELVES		
	36" WIDE	48" WIDE
12" DEEP	6091	6111
18" DEEP	6150	6165
24" DEEP	6185	6198
36" DEEP	6260	—

BACK PANELS			
	42" HIGH	UpTo 84"H	UpTo 120"H
36" WIDE	7506	7506-2	7506-3
48" WIDE	7531	7531-2	7531-3

BASES		
	36" WIDE	48" WIDE
3" HIGH	6924	6930
1-1/2" H	6923	

BIN FRONTS	
3 1/4" HIGH	
36" WIDE	10507
48" WIDE	10508
2 1/8" HIGH	
36" WIDE	10506

REINFORCEMENTS	
FRONT & REAR	
36" WIDE	10029
48" WIDE	9636
CENTER REINF	
36" WIDE	9629
48" WIDE	9637
END REINF	
12" DEEP	9630
18" DEEP	9631
24" DEEP	9632
36" DEEP	9633

LABELHOLDERS	
36" WIDE	6615
48" WIDE	6613

# STANDARD IRON-GRIP SHELVING UNITS

## NOTE:

THE NUMBERS INSIDE THE BINS INDICATE THE NUMBER OF OPEN HOLES ON THE SHELF BETWEEN THE DIVIDERS, OR BETWEEN A DIVIDER AND AN END PANEL.

THE NUMBERS SHOWN BESIDE THE UNITS INDICATE THE SHELF SPACING IN INCHES.

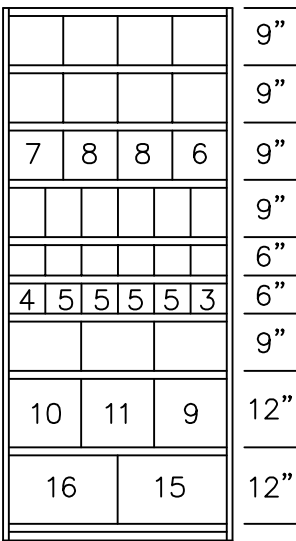

- #1220 - 12" DEEP
- #1222 - 18" DEEP
- #1224 - 24" DEEP

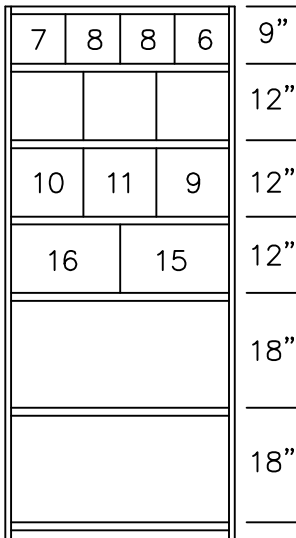

- #1250 - 12" DEEP
- #1252 - 18" DEEP
- #1254 - 24" DEEP

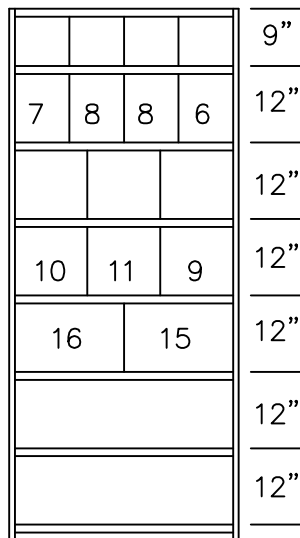

- #1260 - 12" DEEP
- #1262 - 18" DEEP
- #1264 - 24" DEEP

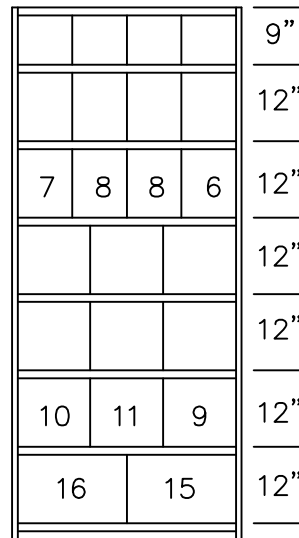

- #1270 - 12" DEEP
- #1272 - 18" DEEP
- #1274 - 24" DEEP

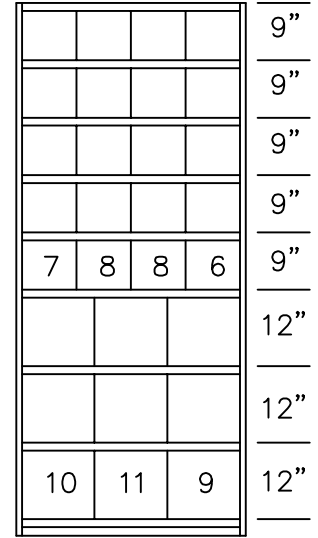

- #1280 - 12" DEEP
- #1282 - 18" DEEP
- #1284 - 24" DEEP

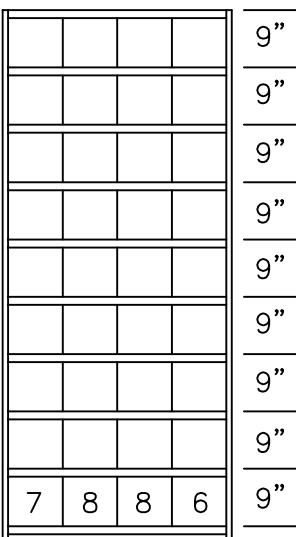

- #1290 - 12" DEEP
- #1292 - 18" DEEP
- #1294 - 24" DEEP

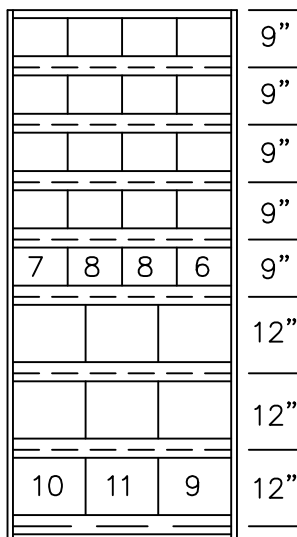

- #1370 - 12" DEEP
- #1372 - 18" DEEP
- #1374 - 24" DEEP

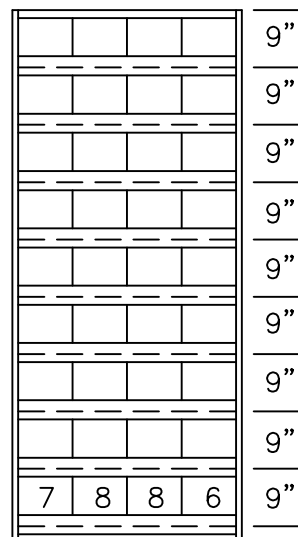

- #1380 - 12" DEEP
- #1382 - 18" DEEP
- #1384 - 24" DEEP

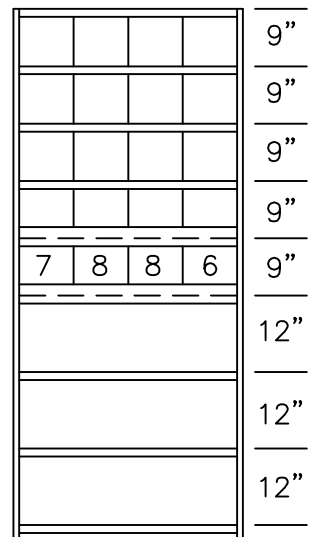

- #1390 - 12" DEEP
- #1392 - 18" DEEP
- #1394 - 24" DEEP



# EQUIPTO

Toll-Free Tel: 800-323-0801  
 Toll-Free Fax: 888-859-2121  
[www.equipto.com](http://www.equipto.com)

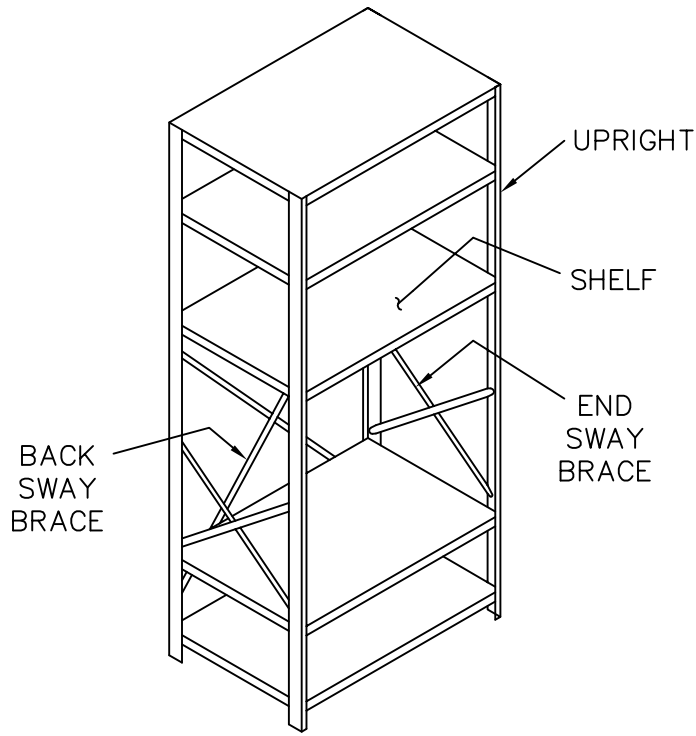

TYPICAL SHELVING UNIT

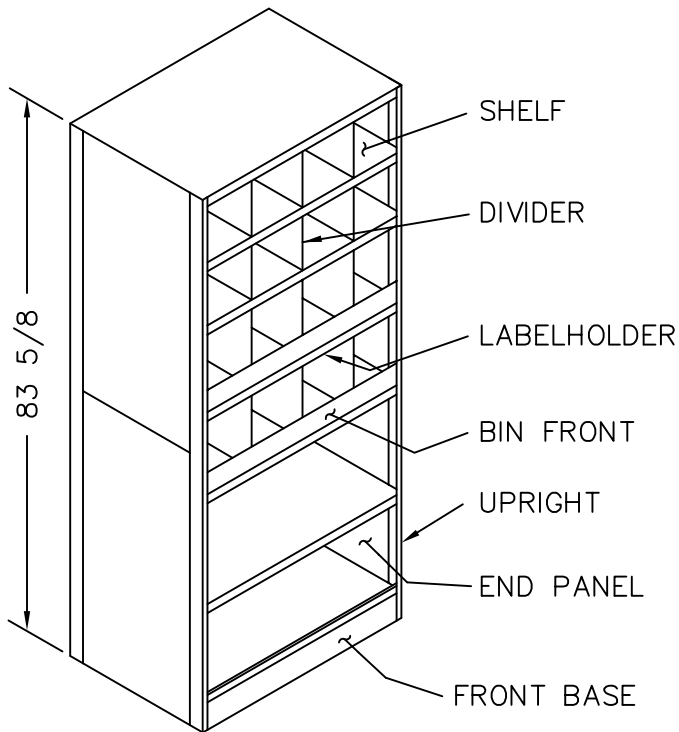
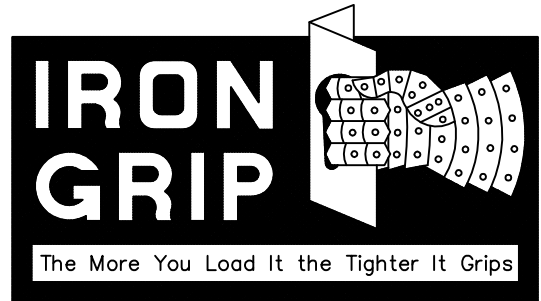

TYPICAL BIN SHELVING UNIT

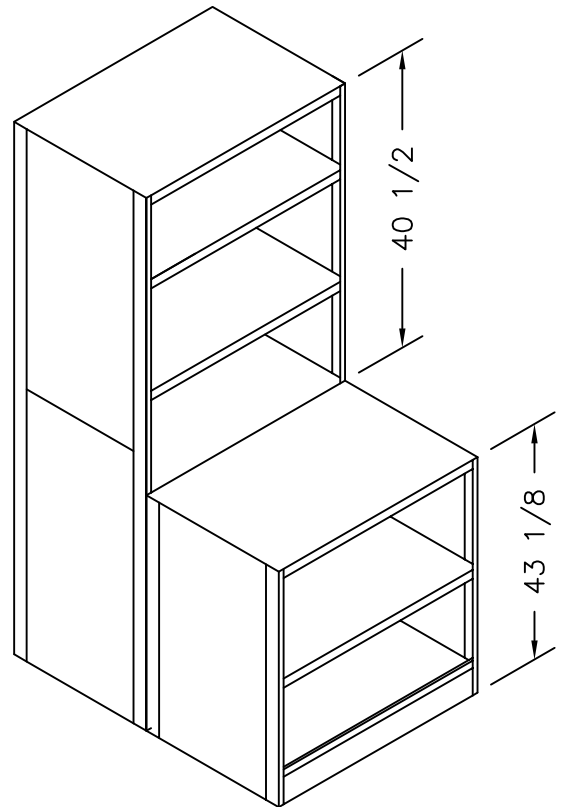

TYPICAL LEDGE SHELVING UNIT