

21111ASY

THIS DRAWING IS THE PROPERTY OF

EQUIPTO

Toll-Free Tel: (800) 323-0801

Toll-Free Fax:(888) 859-2121

www.equipto.com

MODULAR CABINET ASSEMBLY INSTRUCTIONS

A. MODULAR DRAWER CABINET ASSEMBLY

1. MODULAR DRAWER LOCKING SYSTEM ASSEMBLY AS SHOWN IN STEP 1.
2. STACKING CABINETS AS SHOWN IN STEP 2.
HARDWARE FOR STACKING AND ANCHORING TO FLOOR
FURNISHED BY OTHERS.
3. HANDLE, CASTER AND BASE COVER ASSEMBLY AS SHOWN IN
STEP 3.
4. DIVIDERS AND PARTITIONS DESCRIPTION.
5. OPTIONAL MATERIALS AVAILABLE: QUARTER TRAYS, PLASTIC
BINS, GROOVED TRAYS, LOCATOR POSTS AND DRAWER INSERTS.
6. WOOD TOP ASSEMBLY AS SHOWN IN STEP 6.

B. MODULAR CABINET HINGED DOOR ASSEMBLY

1. DOOR LOCKING HANDLE ASSEMBLY AS SHOWN IN STEP 1.
2. HINGED DOOR ASSEMBLY AS SHOWN IN STEP 2.

Step

2

HINGED DOOR ASSEMBLY

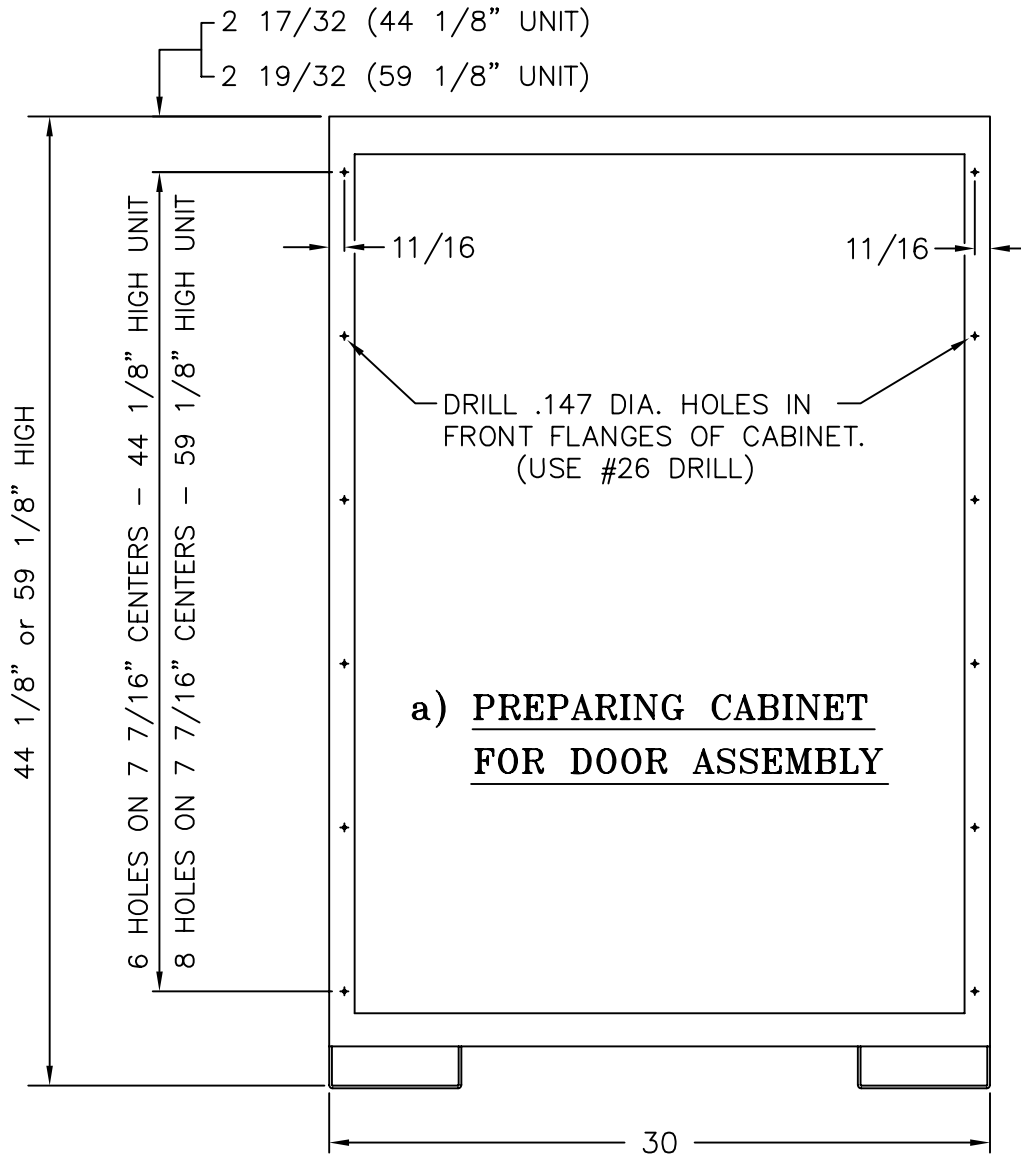

b) HINGED CATCH AND DOOR MOUNTING

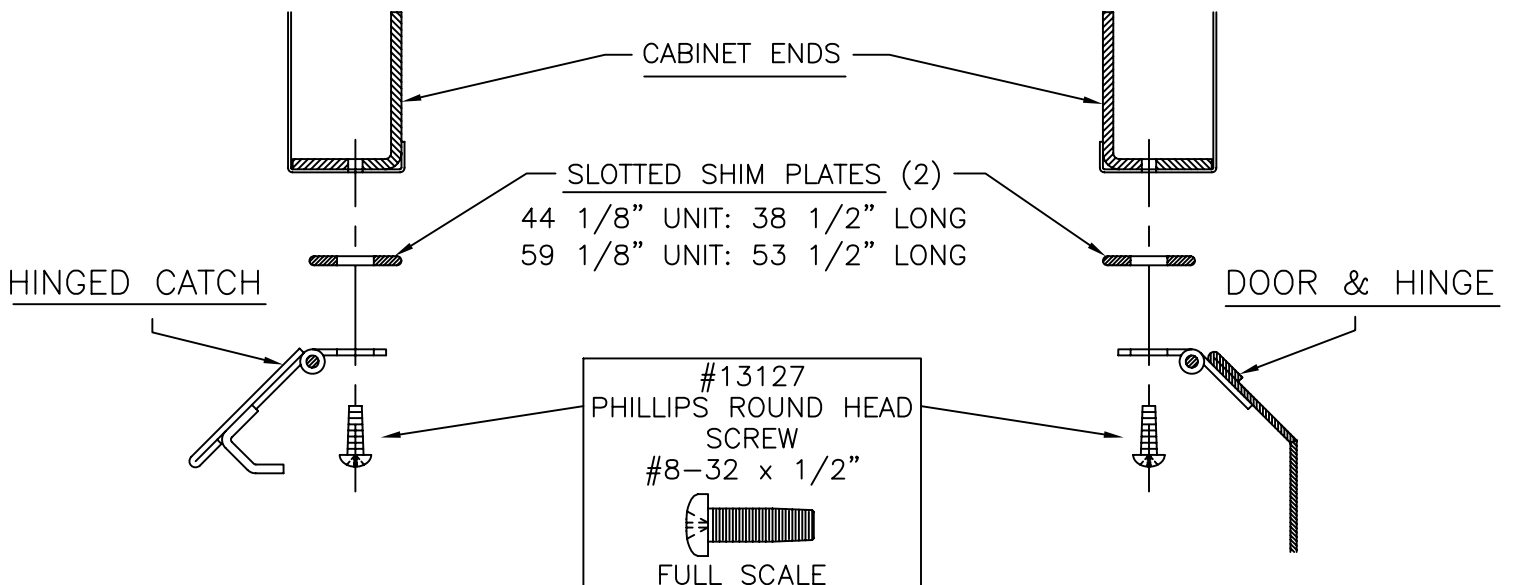

B

HINGED DOOR CABINET ASS'Y

Step

1

LOCKING HANDLE ASSEMBLY

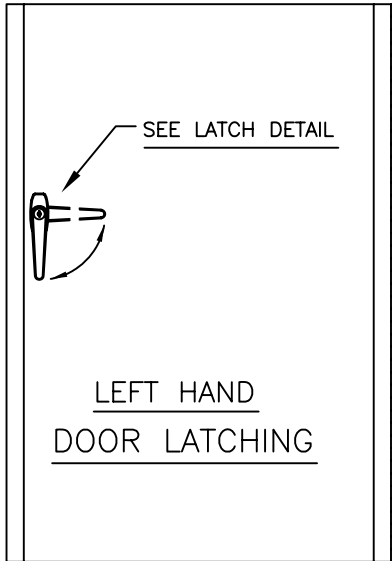

LOCKING HANDLE ASSEMBLY PROCEDURE:

1. POSITION LOCKING HANDLE SO THAT SHANK OF LOCK PASSES THRU THE DOOR PANEL AND FASTEN SECURELY IN PLACE WITH #10-32 x 5/16 SCREWS.
2. SLIDE FLAT WASHER WITH SQUARE HOLE OVER SQUARE SHANK OF LOCK.
3. TELESCOPE #10456 LATCH PLATE OVER SHANK OF LOCK.
4. PLACE THE #13052 CUP WASHER OVER THE END OF THE SQUARE SHANK AND INSERT THE #8-32 x 3/8" SEMS SCREW. TIGHTEN SCREW SECURELY.
5. ROTATE THE HANDLE TO BE CERTAIN LATCHING MECHANISM IS OPERATING PROPERLY.

LEFT HAND LATCH ASSEMBLY

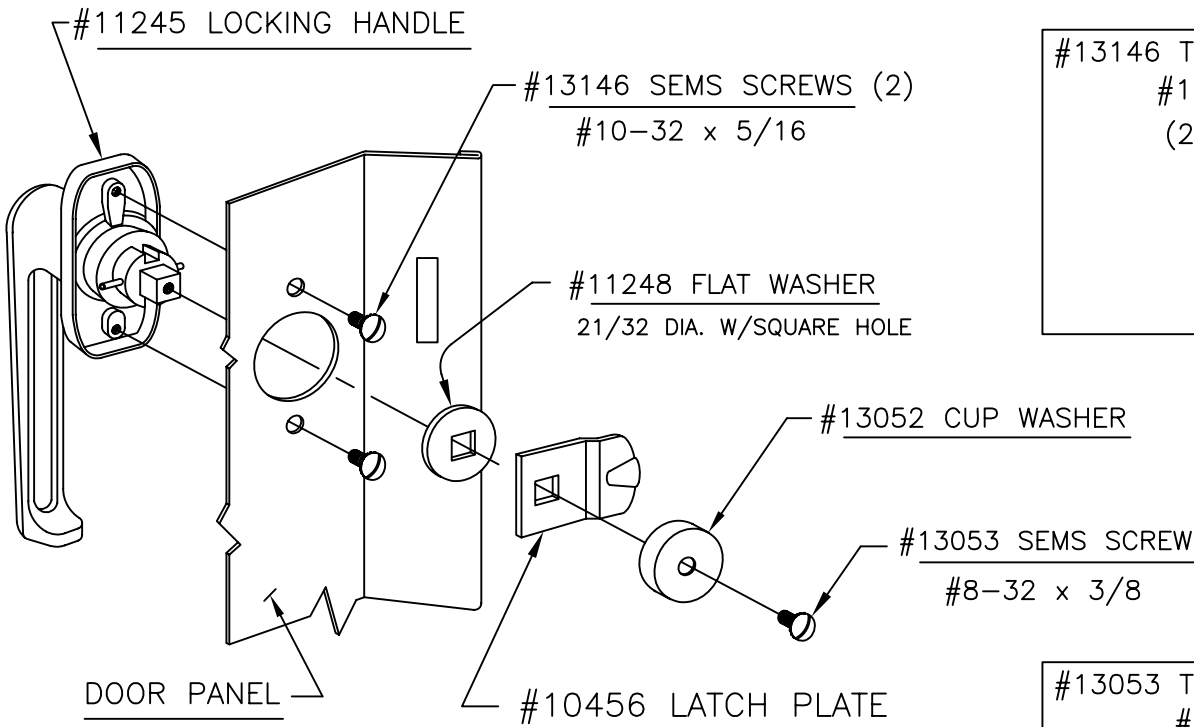

#13146 TRUSS HD MACH SCREW
#10-32 X 5/16"
(2 PER HANDLE)

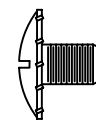

FULL SCALE

#13053 TRUSS HD MACH SCREW
#8-32 X 3/8"
(1 PER HANDLE)

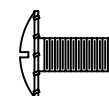

FULL SCALE

NOTE

RIGHT AND LEFT HAND DOOR AVAILABLE.
UNLESS OTHERWISE SPECIFIED, HANDLE
FOR LEFT HAND DOOR HAS BEEN FURNISHED.

Step

6 WOOD TOP ASSEMBLY

LAMINATED MAPLE 1 3/4" THICK

CATALOG NO.	DEPTH X LENGTH
#12302	30" X 30"
#12339	30" X 60"
#12340	30" X 72"

NOTE

THE ROUNDED EDGE OF TOP IS TO BE TOWARD THE FRONT OF THE BENCH.

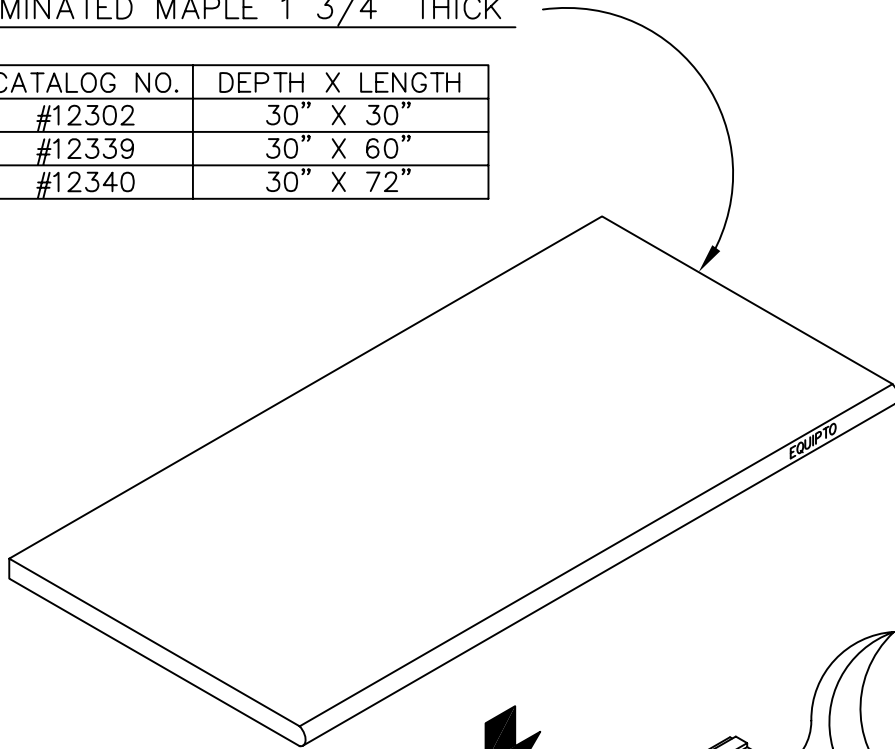

NOTE

USE DOUBLE FACE TAPE (3/4" WIDE) TO STICK THE WOOD TOP ON THE MODULAR CABINETS AS SHOWN.

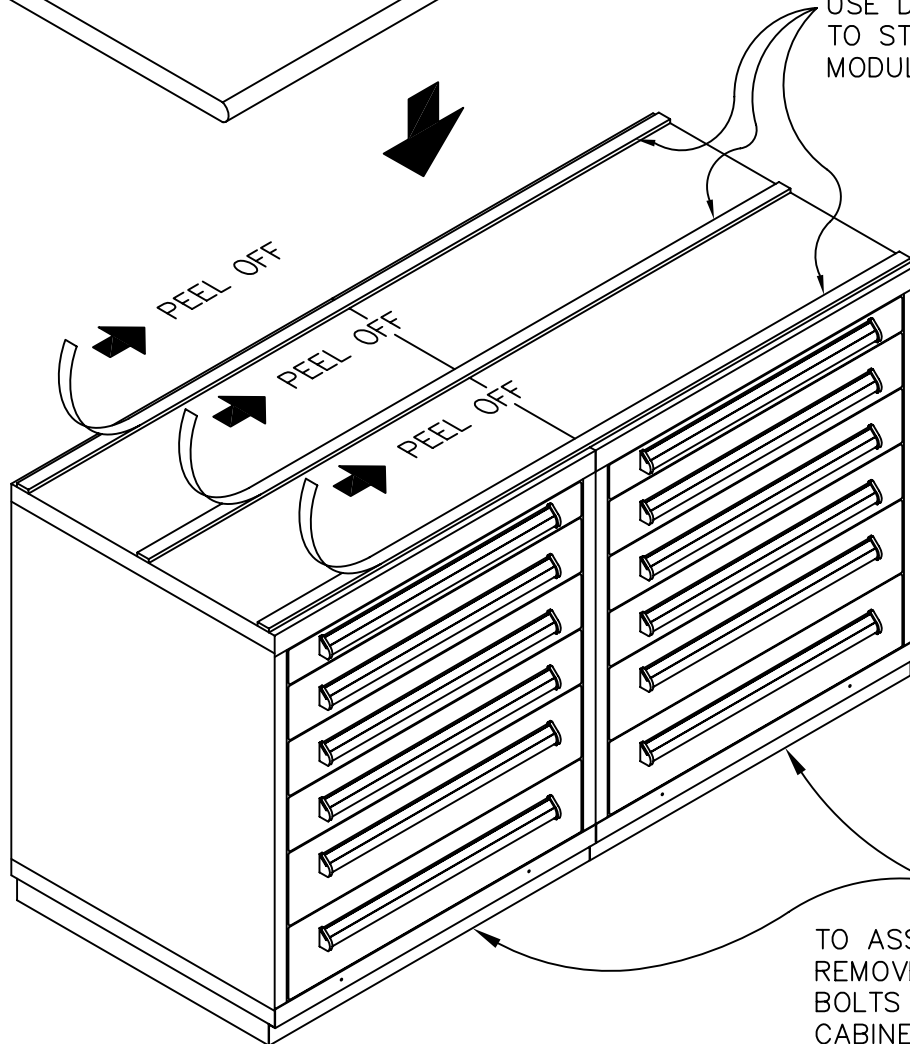

NOTE

TO ASSEMBLE CABINETS TOGETHER: REMOVE TOP TWO DRAWERS AND INSERT BOLTS THROUGH HOLES IN SIDE OF CABINETS. HARDWARE PROVIDED BY BY OTHERS.

Step

5 OPTIONAL MATERIALS AVAILABLE

a) QUARTER TRAYS

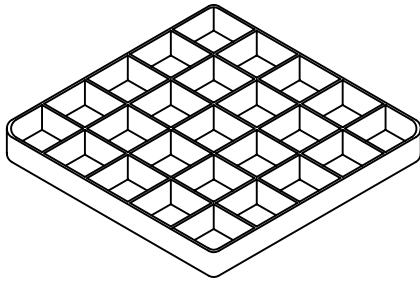

CATALOG NO.	DESCRIPTION
#10120	QUARTER TRAYS (20 COMPARTMENTS) 1 1/4" X 12 1/2" X 12 1/2"
#10121	QUARTER TRAYS (35 COMPARTMENTS) 1 1/4" X 12 1/2" X 12 1/2"

b) PLASTIC BINS

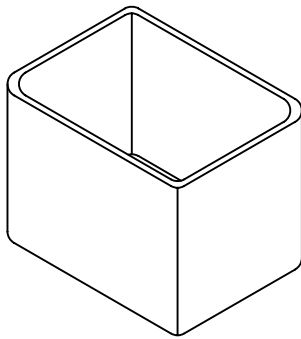

CATALOG NO.	DESCRIPTION
#10122	PLASTIC BINS (96 FILL DRAWER) 2"H X 2"W X 3"L
#10123	PLASTIC BINS (48 FILL DRAWER) 2"H X 3"W X 4"L
#10124	PLASTIC BINS (96 FILL DRAWER) 2 3/4"H X 2"W X 3"L
#10125	PLASTIC BINS (48 FILL DRAWER) 2 3/4"H X 3"W X 4"L

c) GROOVED TRAY

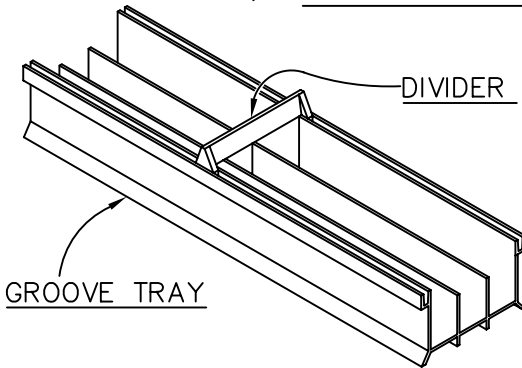

CAT. NO.	DESCRIPTION
#10111	TRAY - 1 GROOVE (ITEMS UP TO 2 5/8" DIA.)
#10112	TRAY - 2 GROOVES (ITEMS UP TO 1 1/4" DIA.)
#10113	TRAY - 3 GROOVES (ITEMS UP TO 13/16" DIA.)
#10114	TRAY - 4 GROOVES (ITEMS UP TO 9/16" DIA.)
#8713	DIVIDER - FOR 1 & 3 GROOVE TRAYS
#8714	DIVIDER - FOR 2 & 4 GROOVE TRAYS

d) LOCATOR POSTS

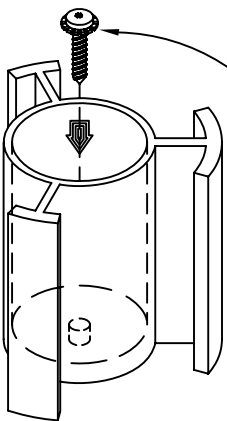

#13099 SCREW

LOCATOR POST
MUST BE USED
WITH #10116
PLYWOOD INSERT
3/8" THICK X
25" X 25".

CAT. NO.	DIAM.	HEIGHT
#10126	15/16"	1"
#10127	15/16"	1 3/4"
#10128	15/16"	2 1/2"
#10129	1 3/16"	1"
#10130	1 3/16"	1 3/4"
#10131	1 3/16"	2 1/2"
#10132	1 7/16"	1"
#10133	1 7/16"	1 3/4"
#10134	1 7/16"	2 1/2"

e) DRAWER INSERTS

CAT. NO.	DESCRIPTION
#10117	1/8" PEGBOARD 25" X 25"
#10118	FELT INSERT 25" X 25"

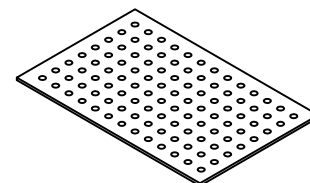

1/8" PEGBOARD

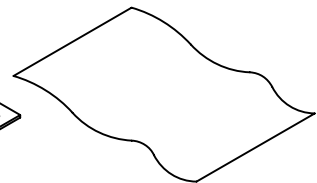

FELT INSERT

#13099 PAN HEAD SHT MET
SCREW #8 X 3/4"
(1 PER POST)

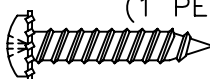

FULL SCALE

Step

4

DIVIDERS AND PARTITIONS

(CONTINUED)

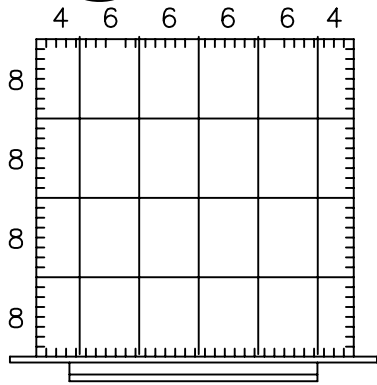

TYPE N

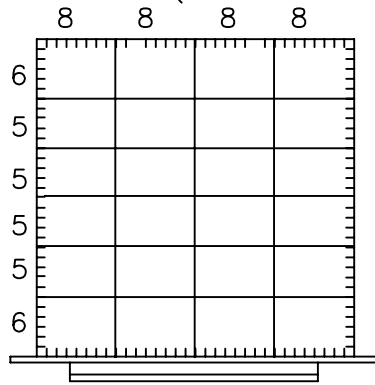

TYPE P

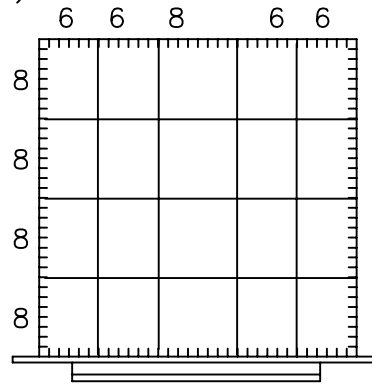

TYPE R

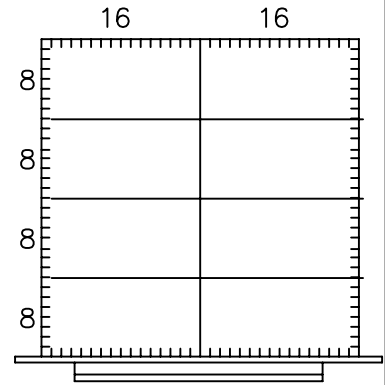

TYPE S

PARTITION CATALOG NUMBERS

MODULAR CABINET WIDTH	HEIGHT OF DRAWER FRONTS				
	3"	4 1/2"	6" AND 7 1/2"	9" AND 10 1/2"	12"
22 1/2" WIDE	8726	8727	8728	8741A	8742A
30", 45" & 60" WIDE	8726	8727	8728		
36" WIDE	18" DEEP	8780	8781	8782	
	24" DEEP	8790	8791	8792	

PARTITION ASSEMBLY

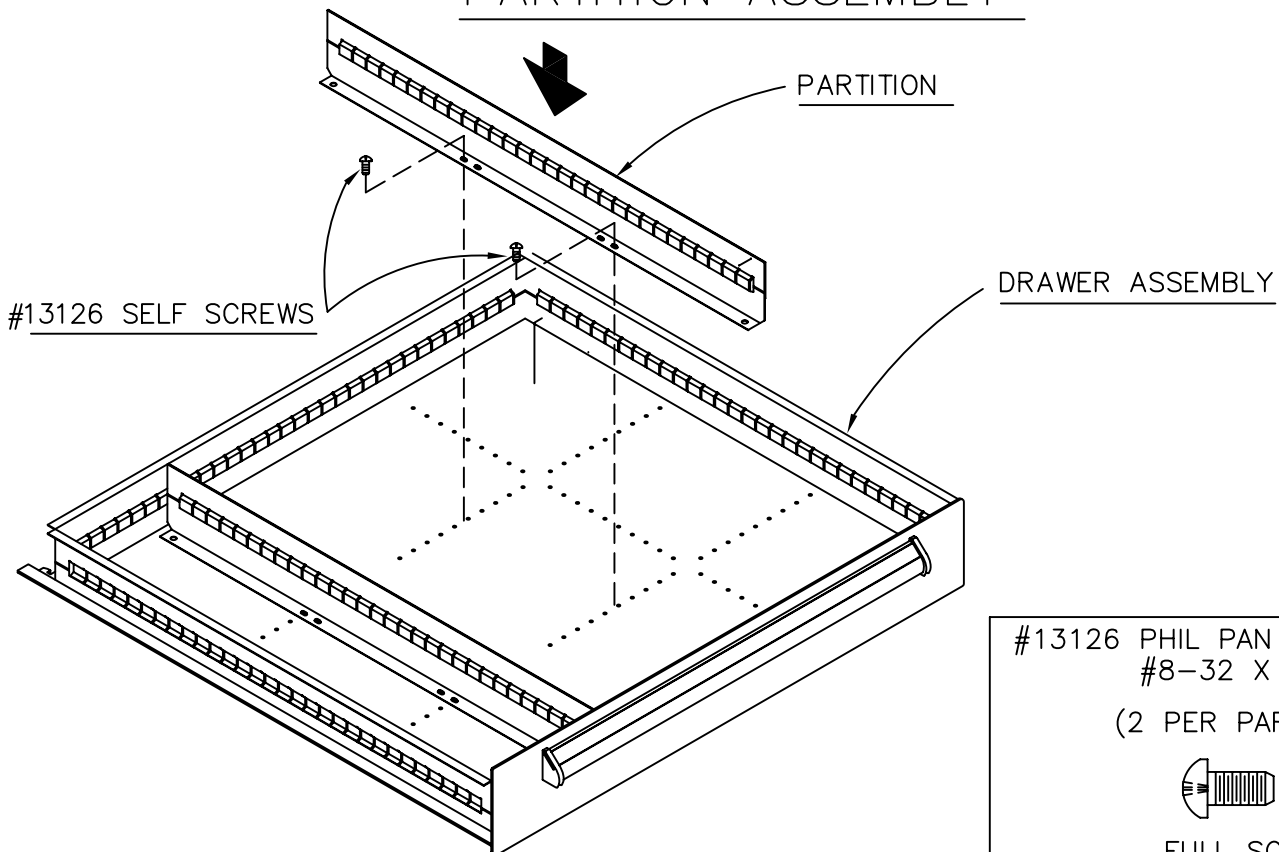

#13126 PHIL PAN HEAD THREAD
#8-32 X 5/16"

(2 PER PARTITION)

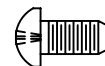

FULL SCALE

Step

4

DIVIDERS AND PARTITIONS

(CONTINUED)

DIVIDERS AND PARTITIONS COMBINATIONS

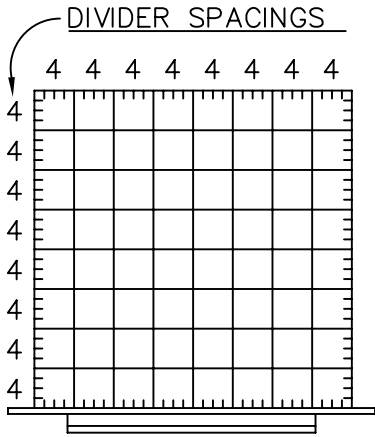

TYPE A

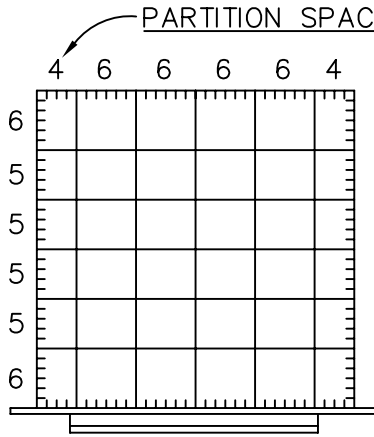

TYPE B

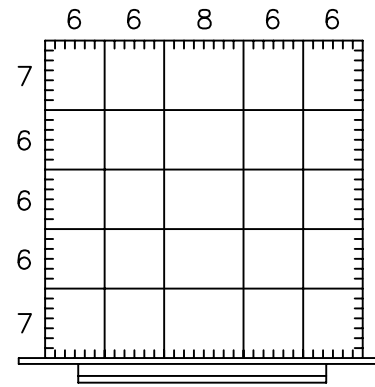

TYPE C

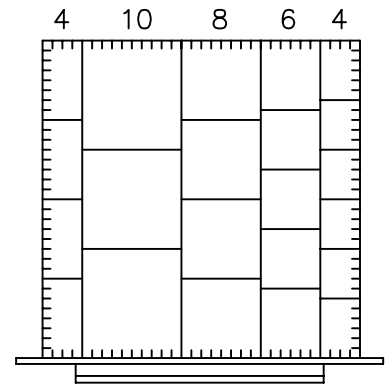

TYPE D

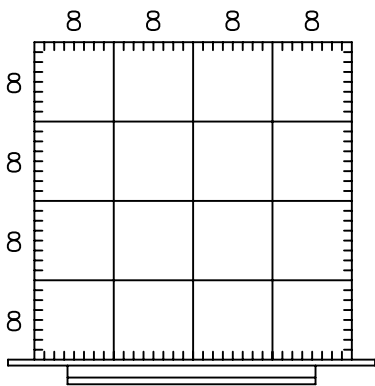

TYPE E

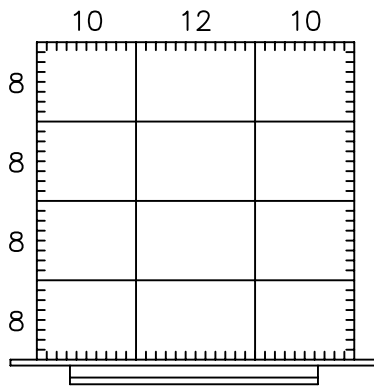

TYPE F

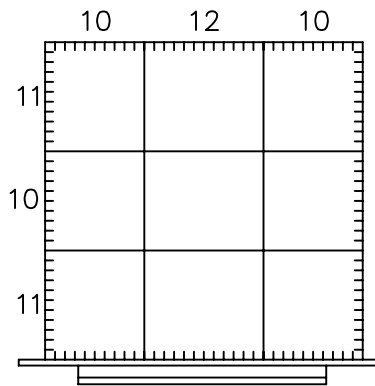

TYPE G

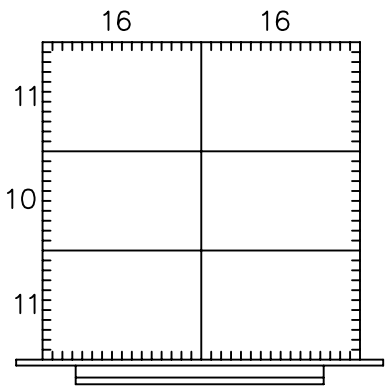

TYPE H

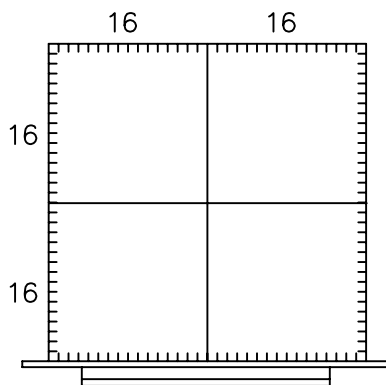

TYPE K

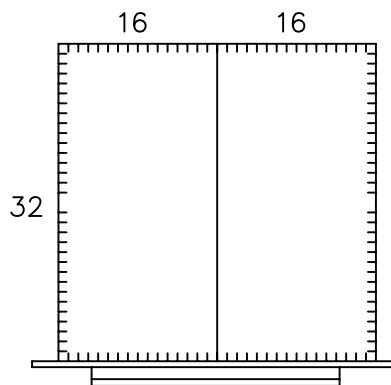

TYPE L

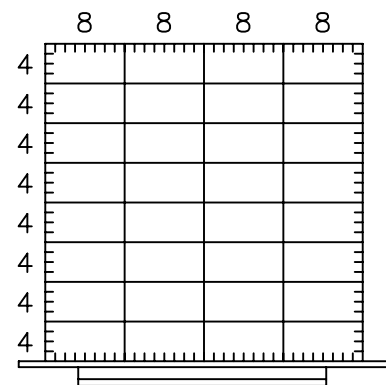

TYPE M

Step

4

DIVIDERS AND PARTITIONS

DIVIDER SET CATALOG NUMBERS

MODULAR CABINET WIDTH		DIVIDER SET DESCRIPTION	HEIGHT OF DRAWER FRONTS				
			3"	4 1/2"	6" AND 7 1/2"	9" AND 10 1/2"	12"
22 1/2" WIDE	Type D	4163D10	4164D15	4165D20	4167D30	4169D40	
	Type G	4163G10	4164G15	4165G20	4167G30	4169G40	
	Type H	4163H10	4164H15	4165H20	4167H30	4169H40	
30" WIDE	Type A	4133A10	4134A15	4135A20			
	Type B	4133B10	4134B15	4135B20			
	Type C	4133C10	4134C15	4135C20			
	Type D	4133D10	4134D15	4135D20			
	Type E	4133E10	4134E15	4135E20			
	Type F	4133F10	4134F15	4135F20			
	Type G	4133G10	4134G15	4135G20			
	Type H	4133H10	4134H15	4135H20			
	Type K	4133K10	4134K15	4135K20			
	Type L	4133L10	4134L15	4135L20			
Type M	4133M10	4134M15	4135M20				
36" WIDE	18" DEEP	Type D	4173D10	4174D15	4175D20		
	24" DEEP	Type D	4183D10	4184D15	4185D20		
45" WIDE	Type D	4143D10	4144D15	4145D20			
60" WIDE	Type D	4153D10	4154D15	4155D20			

DIVIDER CATALOG NUMBERS

DIVIDER WIDTH	HEIGHT OF DRAWER FRONTS				
	3"	4 1/2"	6" AND 7 1/2"	9" AND 10 1/2"	12"
3 3/32" (4 Spaces)	8834	8844	8854	8864	8874
4 11/16" (6 Spaces)	8835	8845	8855	8865	8875
6 9/32" (8 Spaces)	8836	8846	8856	8866	8876
7 7/8" (10 Spaces)	8837	8847	8857	8867	8877
9 7/16" (12 Spaces)	8838	8848	8858	8868	8878
12 11/16" (16 Spaces)	8839	8849	8859	8869	8879

NOTE

USE #13126 SELF TAPPING SCREWS FOR 12 11/16" WIDE DIVIDERS.

#13126 PHIL PAN HEAD SCREW
#8-32 X 5/16"

(1 PER DIVIDER)

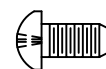

FULL SCALE

Step

3

HANDLE, CASTER AND BASE COVER ASS'Y

a) HANDLE ASSEMBLY

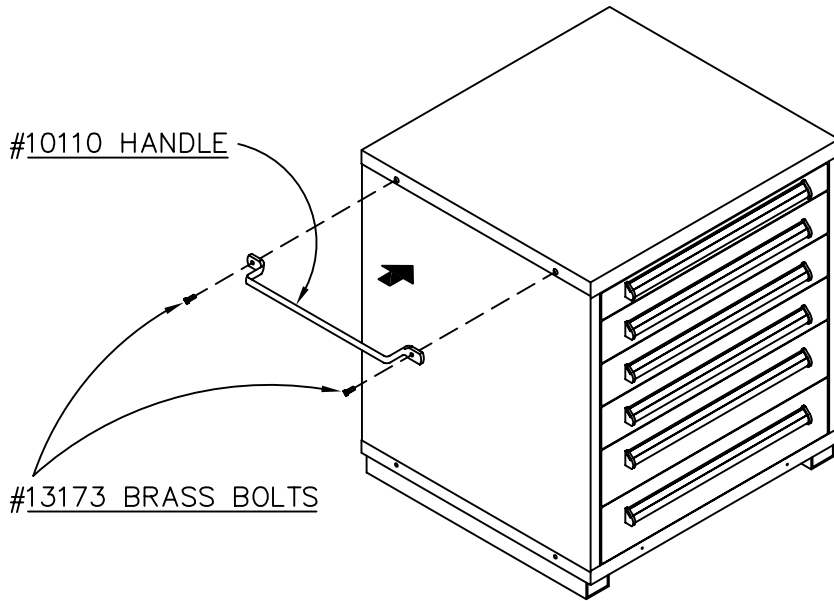

#13173 HEX HD CAP SCREW
5/16" x 3/4"
(2 PER HANDLE)

#13051 TWIN WHIZZ LOCKNUT
5/16"-18

#13175 FLAT WASHER 5/16"

FULL SCALE

b) CASTER ASSEMBLY

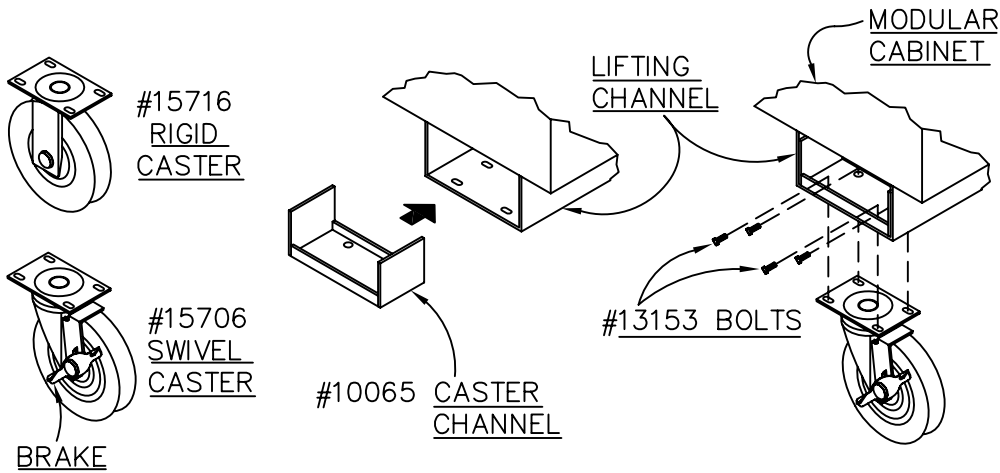

#13153 HEX HD CAP SCREW
5/16"-18

#13051 TWIN WHIZZ LOCKNUT
5/16"-18

#13175 FLAT WASHER 5/16"
(4 PER CASTER)

FULL SCALE

c) BASE COVER ASSEMBLY

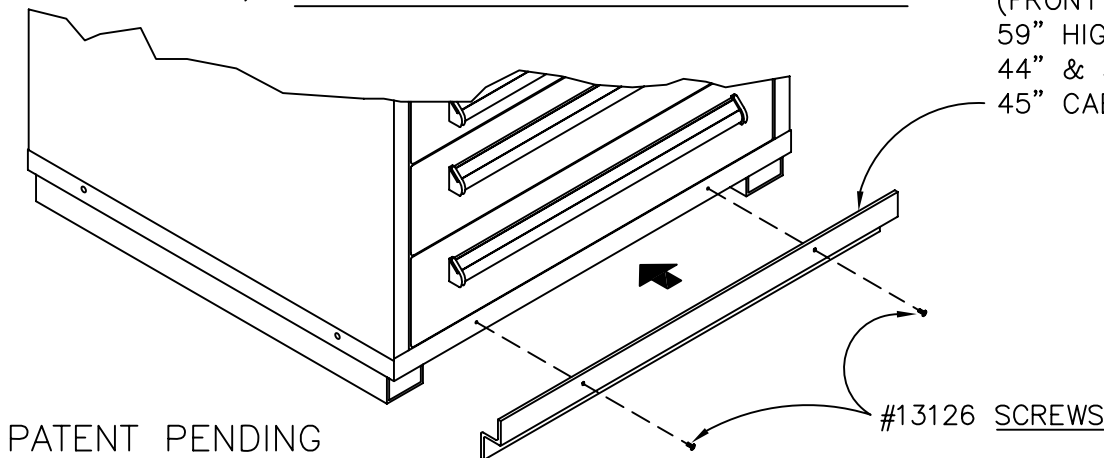

#6838 FRONT LIFTING BASE COVER
(FRONT AND REAR FOR: 30" CAB. 29" & 33" HIGH, AND FOR 22-1/2" CAB. 29" & 33" HIGH)
(FRONT ONLY FOR: 30" CAB. 44" & 59" HIGH, AND FOR 22-1/2" CAB. 44" & 59" HIGH, AND FOR 36" AND 45" CAB. ALL HEIGHTS)

#13126 PHILLIPS PAN HEAD SCREW
#8-32 x 5/16"
(2 PER COVER)

FULL SCALE

Step

2

STACKING CABINETS

FIELD DRILL CABINET FOR STACKING

DRILL FOUR HOLES USING A $17/32$ " DIA. DRILL BIT.

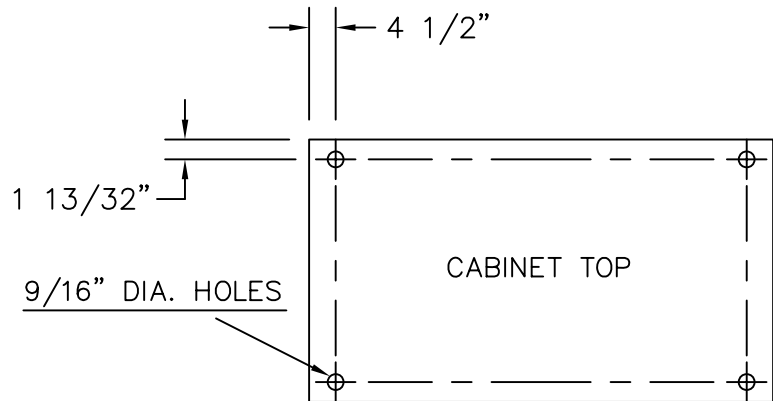
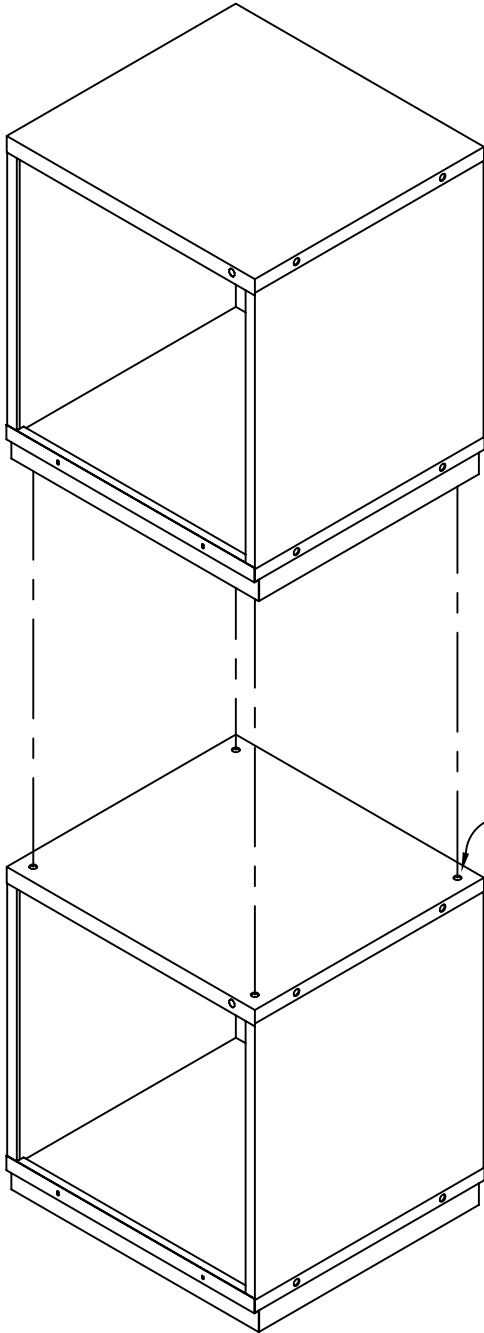

FIELD MODIFY

CAUTION!!!

CABINET MAY TIP FORWARD IF MORE THAN ONE FULLY LOADED DRAWER IS OPENED AT THE SAME TIME.

NOTE

HARDWARE FOR STACKING AND ANCHORING TO FLOOR FURNISHED BY OTHERS.

A MODULAR DRAWER CABINET ASS'Y

Step

1

LOCK ASSEMBLY

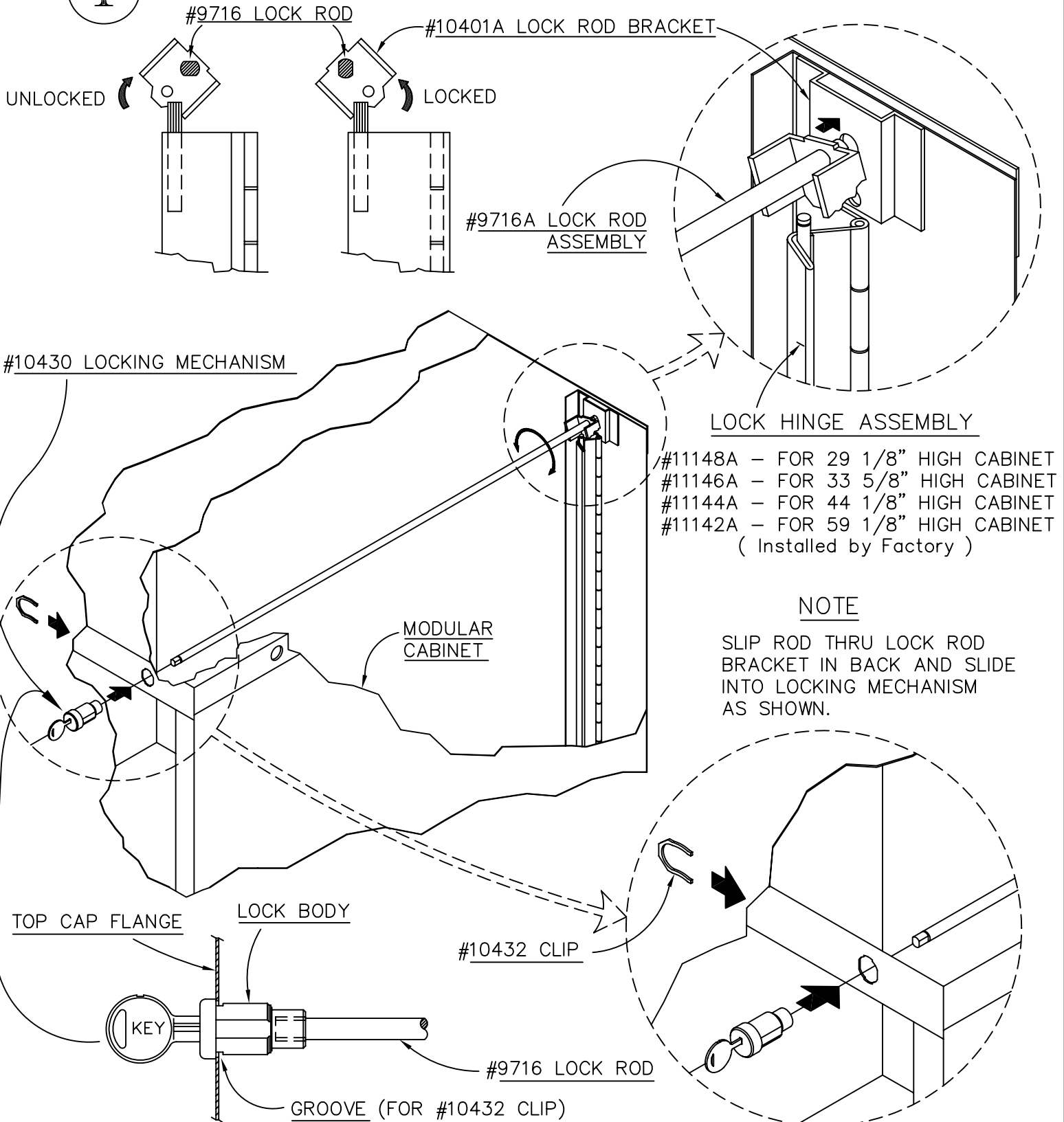

THIS DRAWING IS THE PROPERTY OF

EQUIPTO

Toll-Free Tel: 800-323-0801

Toll Free Fax: 888-859-2121

www.equipto.com

21111ASY