

21111ASY

---

**EQUIPTO**

---

Modular Drawer Cabinet  
Assembly Instructions

**READ INSTRUCTIONS BEFORE ASSEMBLING**

Toll-free Tel: 800-323-0801    Toll-free Fax: 888-859-2121    [www.equipto.com](http://www.equipto.com)

© EQUIPTO 2008

# TABLE OF CONTENTS

## A. MODULAR DRAWER CABINET ASSEMBLY

1. MODULAR DRAWER LOCKING SYSTEM ASSEMBLY. (OPTIONAL)
2. STACKING CABINETS.  
HARDWARE FOR STACKING AND ANCHORING TO FLOOR  
FURNISHED BY OTHERS.
3. HANDLE, CASTER AND BASE COVER ASSEMBLY
4. DIVIDERS AND PARTITIONS DESCRIPTION.
5. OPTIONAL MATERIALS AVAILABLE: QUARTER TRAYS, PLASTIC  
BINS, LOCATOR POSTS AND DRAWER INSERTS.
6. WOOD TOP ASSEMBLY.

## B. MODULAR CABINET HINGED DOOR ASSEMBLY

1. DOOR LOCKING HANDLE ASSEMBLY.
2. HINGED DOOR ASSEMBLY.

# A MODULAR DRAWER CABINET ASS'Y

## Step

### 1 LOCK ASSEMBLY (OPTIONAL)

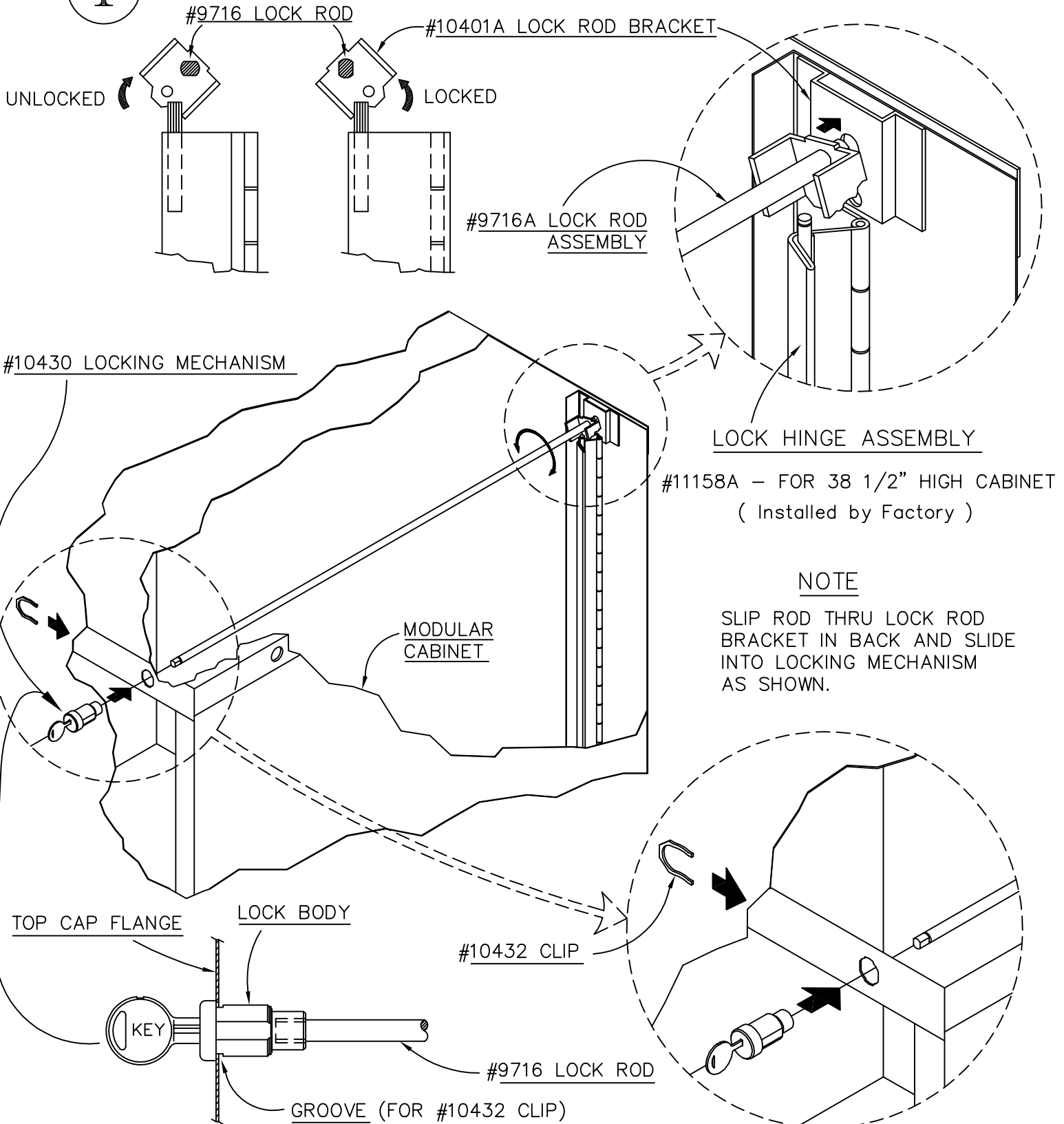

# Step

2

## STACKING CABINETS

### FIELD DRILL CABINET FOR STACKING

DRILL FOUR HOLES USING A  $17/32$ " DIA. DRILL BIT.

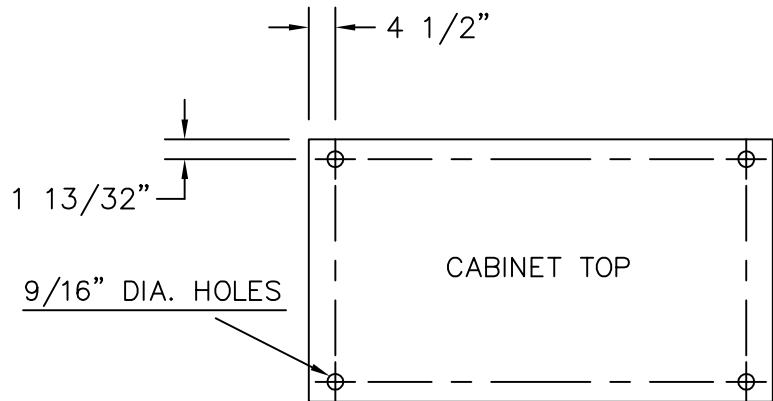
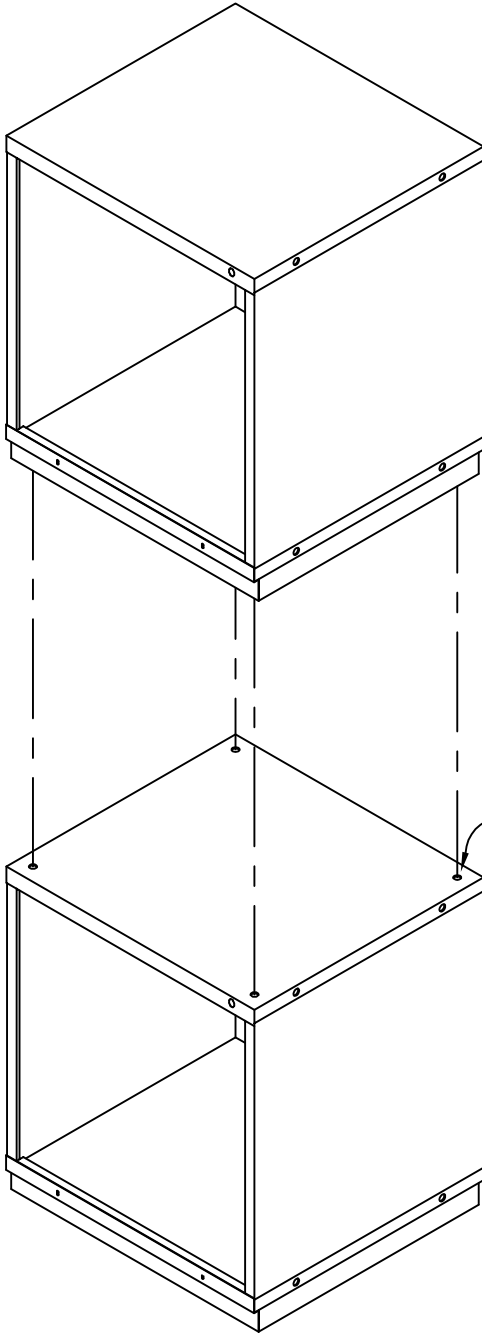

FIELD MODIFY

### CAUTION!!!

CABINET MAY TIP FORWARD IF MORE THAN ONE FULLY LOADED DRAWER IS OPENED AT THE SAME TIME.

### NOTE

HARDWARE FOR STACKING AND ANCHORING TO FLOOR FURNISHED BY OTHERS.

# Step

## 3

# HANDLE, CASTER AND BASE COVER ASS'Y

### a) HANDLE ASSEMBLY

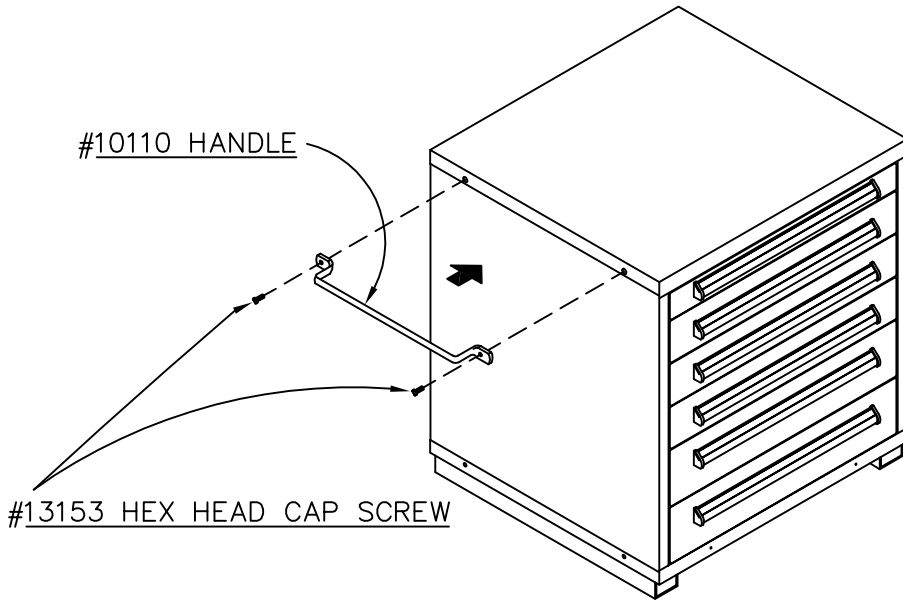

#13153 HEX HD CAP SCREW  
5/16" x 3/4"  
(2 PER HANDLE)

#13051 TWIN WHIZZ LOCKNUT  
5/16"-18

#13175 FLAT WASHER 5/16"

FULL SCALE

### b) CASTER ASSEMBLY

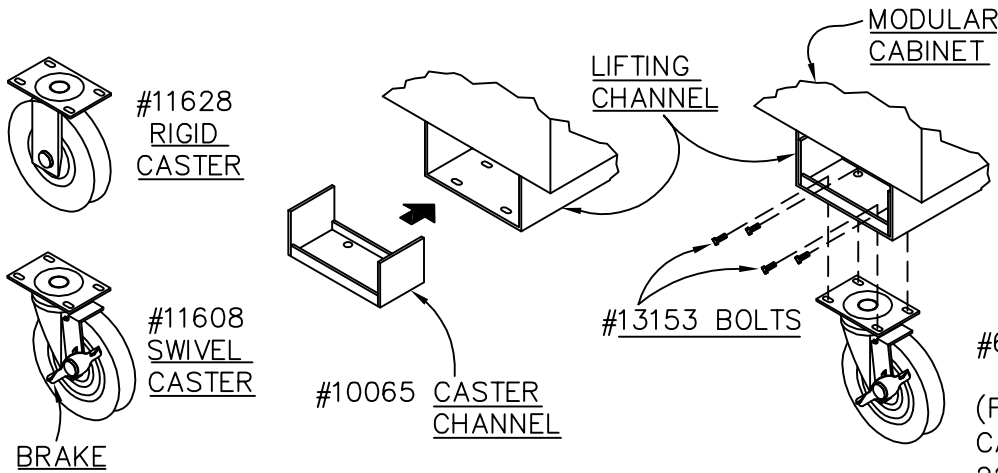

#13153 HEX HD CAP SCREW  
5/16"-18

#13051 TWIN WHIZZ LOCKNUT  
5/16"-18

#13175 FLAT WASHER 5/16"  
(4 PER CASTER)

FULL SCALE

### c) BASE COVER ASSEMBLY

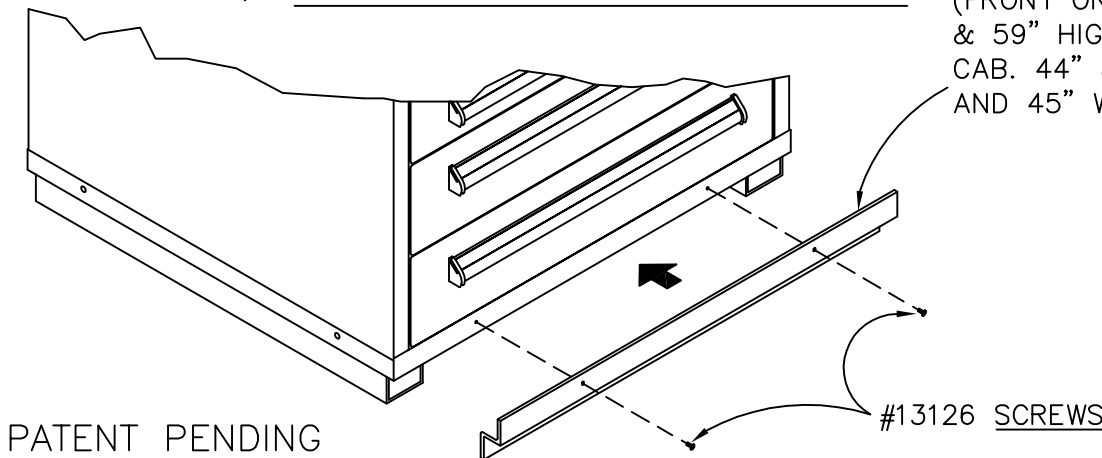

(FRONT AND REAR FOR: 30" WIDE CAB. 29" & 33" HIGH, AND FOR 22-1/2" WIDE CAB. 29" & 33" HIGH)

(FRONT ONLY FOR: 30" WIDE CAB. 44" & 59" HIGH, AND FOR 22-1/2" WIDE CAB. 44" & 59" HIGH, AND FOR 36" AND 45" WIDE CAB. ALL HEIGHTS)

#13126 PHILLIPS PAN HEAD SCREW  
#8-32 x 5/16"  
(2 PER COVER)

FULL SCALE

# Step

## 4

# DIVIDERS AND PARTITIONS

## DIVIDER SET CATALOG NUMBERS

MODULAR CABINET WIDTH	DIVIDER SET DESCRIPTION	HEIGHT OF DRAWER FRONTS				
		3"	4 1/2"	6" AND 7 1/2"	9" AND 10 1/2"	12"
22 1/2" WIDE	Type D	4163D10	4164D15	4165D20	4167D30	4169D40
	Type G	4163G10	4164G15	4165G20	4167G30	4169G40
	Type H	4163H10	4164H15	4165H20	4167H30	4169H40
30" WIDE	Type A	4133A10	4134A15	4135A20		
	Type B	4133B10	4134B15	4135B20		
	Type C	4133C10	4134C15	4135C20		
	Type D	4133D10	4134D15	4135D20		
	Type E	4133E10	4134E15	4135E20		
	Type F	4133F10	4134F15	4135F20		
	Type G	4133G10	4134G15	4135G20		
	Type H	4133H10	4134H15	4135H20		
	Type K	4133K10	4134K15	4135K20		
	Type L	4133L10	4134L15	4135L20		
Type M	4133M10	4134M15	4135M20			
36" WIDE	18" DEEP	Type D	4173D10	4174D15	4175D20	
	24" DEEP	Type D	4183D10	4184D15	4185D20	
45" WIDE	Type D	4143D10	4144D15	4145D20		
60" WIDE	Type D	4153D10	4154D15	4155D20		

## DIVIDER CATALOG NUMBERS

DIVIDER WIDTH	HEIGHT OF DRAWER FRONTS				
	3"	4 1/2"	6" AND 7 1/2"	9" AND 10 1/2"	12"
3 3/32" (4 Spaces)	8834	8844	8854	8864	8874
4 11/16" (6 Spaces)	8835	8845	8855	8865	8875
6 9/32" (8 Spaces)	8836	8846	8856	8866	8876
7 7/8" (10 Spaces)	8837	8847	8857	8867	8877
9 7/16" (12 Spaces)	8838	8848	8858	8868	8878
12 11/16" (16 Spaces)	8839	8849	8859	8869	8879

### NOTE

USE #13126 SELF TAPPING SCREWS FOR 12 11/16" WIDE DIVIDERS.

#13126 PHIL PAN HEAD SCREW  
#8-32 X 5/16"

(1 PER DIVIDER)

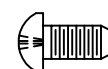

FULL SCALE

# Step

# 4

## DIVIDERS AND PARTITIONS

(CONTINUED)

### DIVIDERS AND PARTITIONS COMBINATIONS

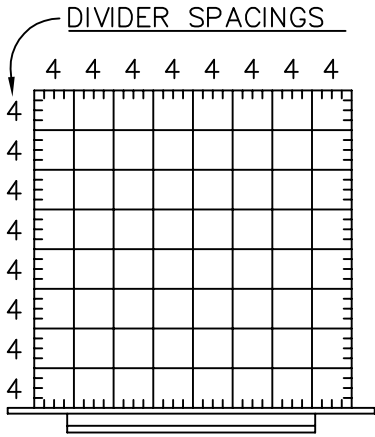

TYPE A

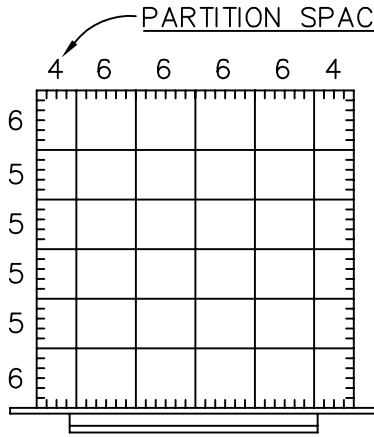

TYPE B

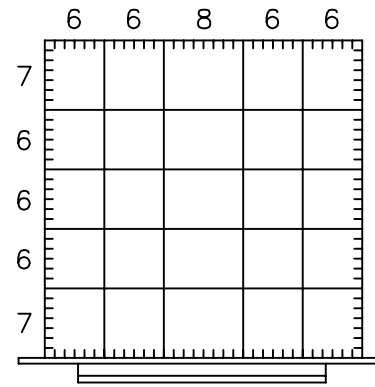

TYPE C

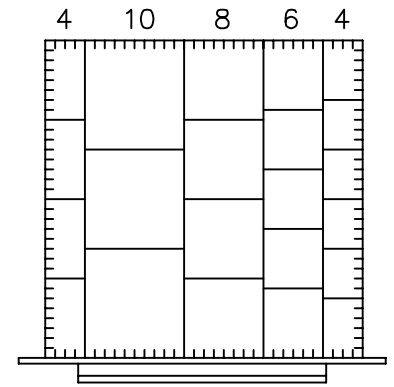

TYPE D

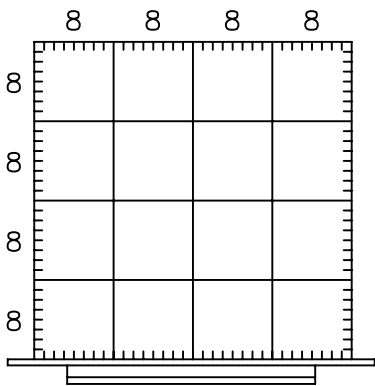

TYPE E

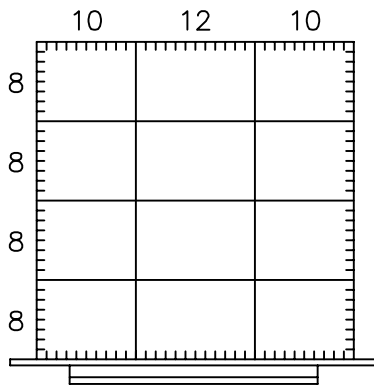

TYPE F

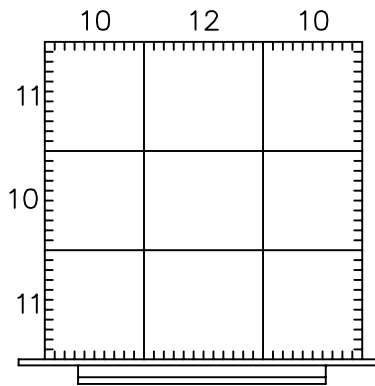

TYPE G

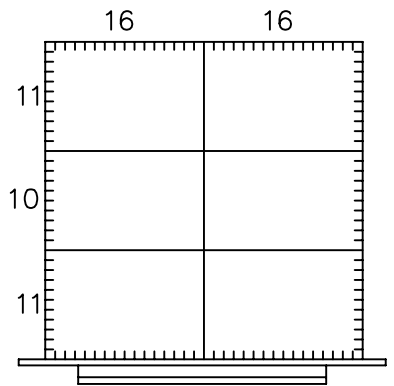

TYPE H

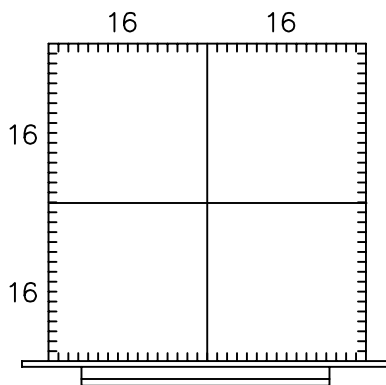

TYPE K

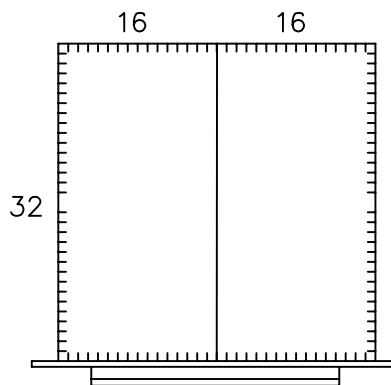

TYPE L

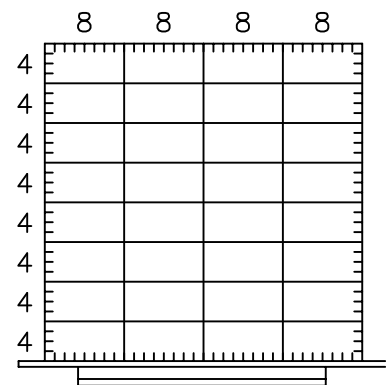

TYPE M

# Step

4

## DIVIDERS AND PARTITIONS

(CONTINUED)

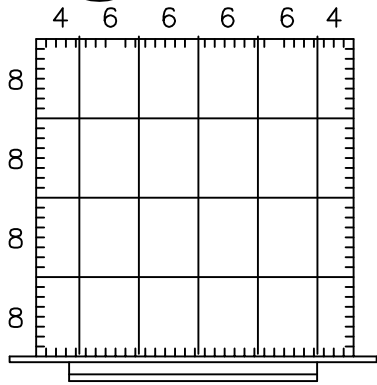

TYPE N

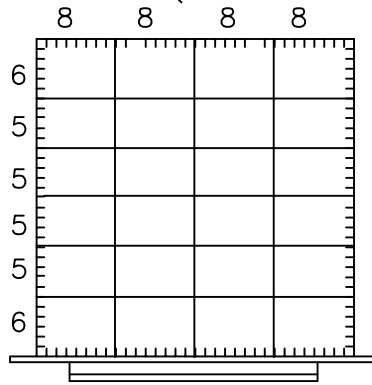

TYPE P

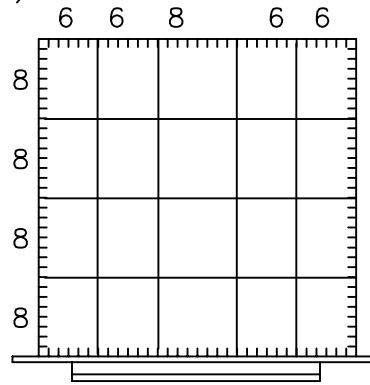

TYPE R

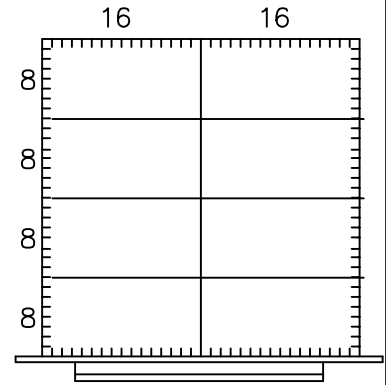

TYPE S

### PARTITION CATALOG NUMBERS

MODULAR CABINET WIDTH	HEIGHT OF DRAWER FRONTS				
	3"	4 1/2"	6" AND 7 1/2"	9" AND 10 1/2"	12"
22 1/2" WIDE	8726	8727	8728	8741A	8742A
30", 45" & 60" WIDE	8726	8727	8728		
36" WIDE	18" DEEP	8780	8781	8782	
	24" DEEP	8790	8791	8792	

### PARTITION ASSEMBLY

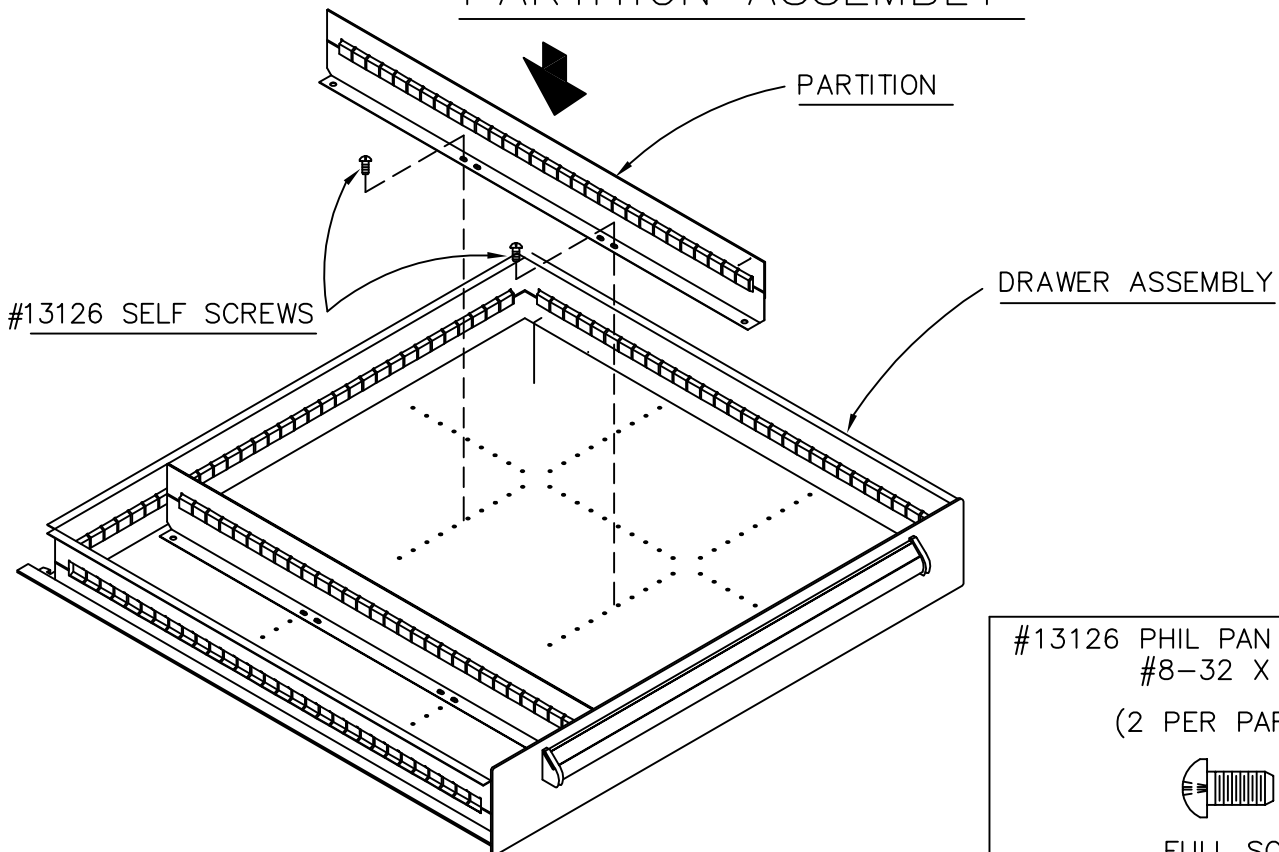

#13126 PHIL PAN HEAD THREAD  
#8-32 X 5/16"  
(2 PER PARTITION)

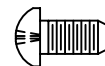

FULL SCALE



# Step

5

## OPTIONAL MATERIALS AVAILABLE

### a) QUARTER TRAYS

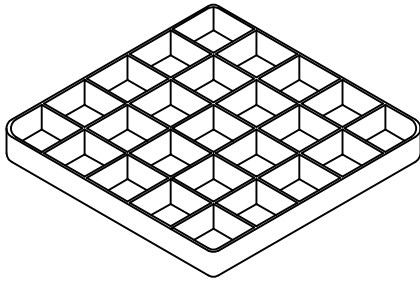

CATALOG NO.	DESCRIPTION
#10120	QUARTER TRAYS (20 COMPARTMENTS) 1 1/4" X 12 1/2" X 12 1/2"
#10121	QUARTER TRAYS (35 COMPARTMENTS) 1 1/4" X 12 1/2" X 12 1/2"

### b) PLASTIC BINS

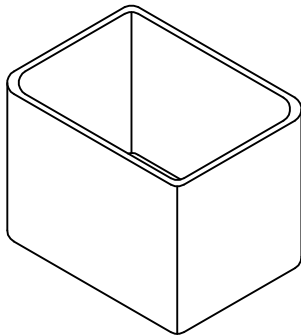

CATALOG NO.	DESCRIPTION
#10122	PLASTIC BINS (96 FILL DRAWER) 2"H X 2"W X 3"L
#10123	PLASTIC BINS (48 FILL DRAWER) 2"H X 3"W X 4"L
#10124	PLASTIC BINS (96 FILL DRAWER) 2 3/4"H X 2"W X 3"L
#10125	PLASTIC BINS (48 FILL DRAWER) 2 3/4"H X 3"W X 4"L

### c) LOCATOR POSTS

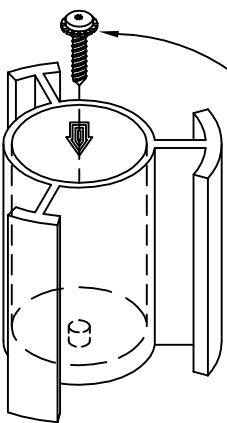

#13099 SCREW

LOCATOR POST  
MUST BE USED  
WITH #10116  
PLYWOOD INSERT  
3/8" THICK X  
25" X 25".

CAT. NO.	DIAM.	HEIGHT
#10126	15/16"	1"
#10127	15/16"	1 3/4"
#10128	15/16"	2 1/2"
#10129	1 3/16"	1"
#10130	1 3/16"	1 3/4"
#10131	1 3/16"	2 1/2"
#10132	1 7/16"	1"
#10133	1 7/16"	1 3/4"
#10134	1 7/16"	2 1/2"

### d) DRAWER INSERTS

CAT. NO.	DESCRIPTION
#10116	3/8" plywood 25" X 25"

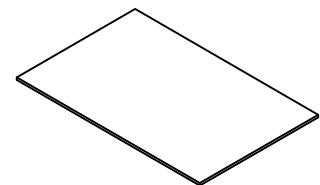

#13099 PAN HEAD SHT MET  
SCREW #8 X 7/8"  
(1 PER POST)



FULL SCALE

# Step

## 6 WOOD TOP ASSEMBLY

SOLID LAMINATED HARDWOOD TOP 1 3/4" THICK

CATALOG NO.	DEPTH X LENGTH
#12302	30" X 30"
#12339	30" X 60"
#12340	30" X 72"

### NOTE

THE ROUNDED EDGE OF TOP IS TO BE TOWARD THE FRONT OF THE BENCH.

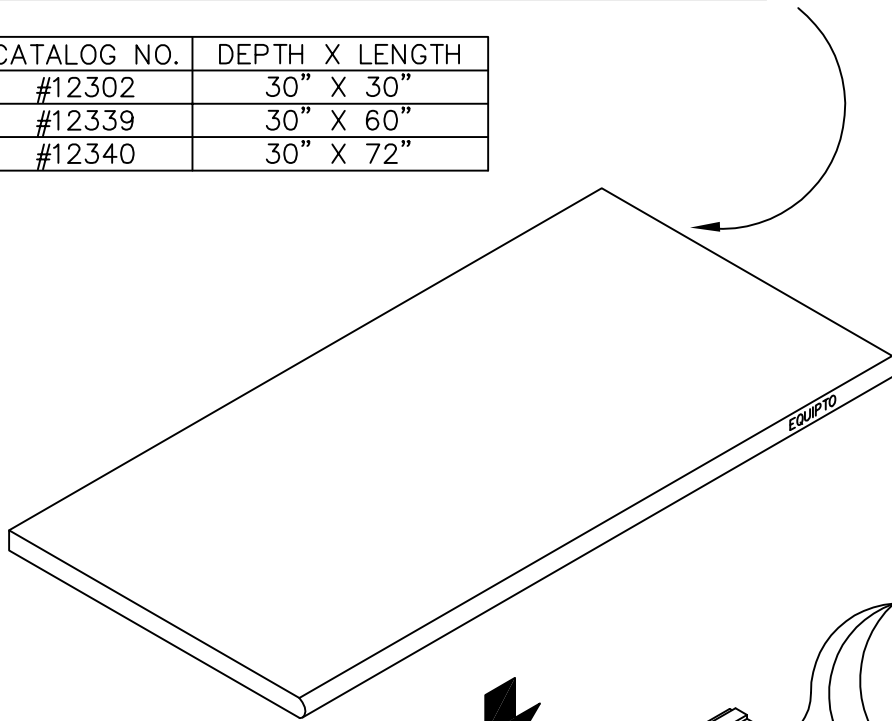

### NOTE

USE DOUBLE FACE TAPE (3/4" WIDE) TO STICK THE WOOD TOP ON THE MODULAR CABINETS AS SHOWN.

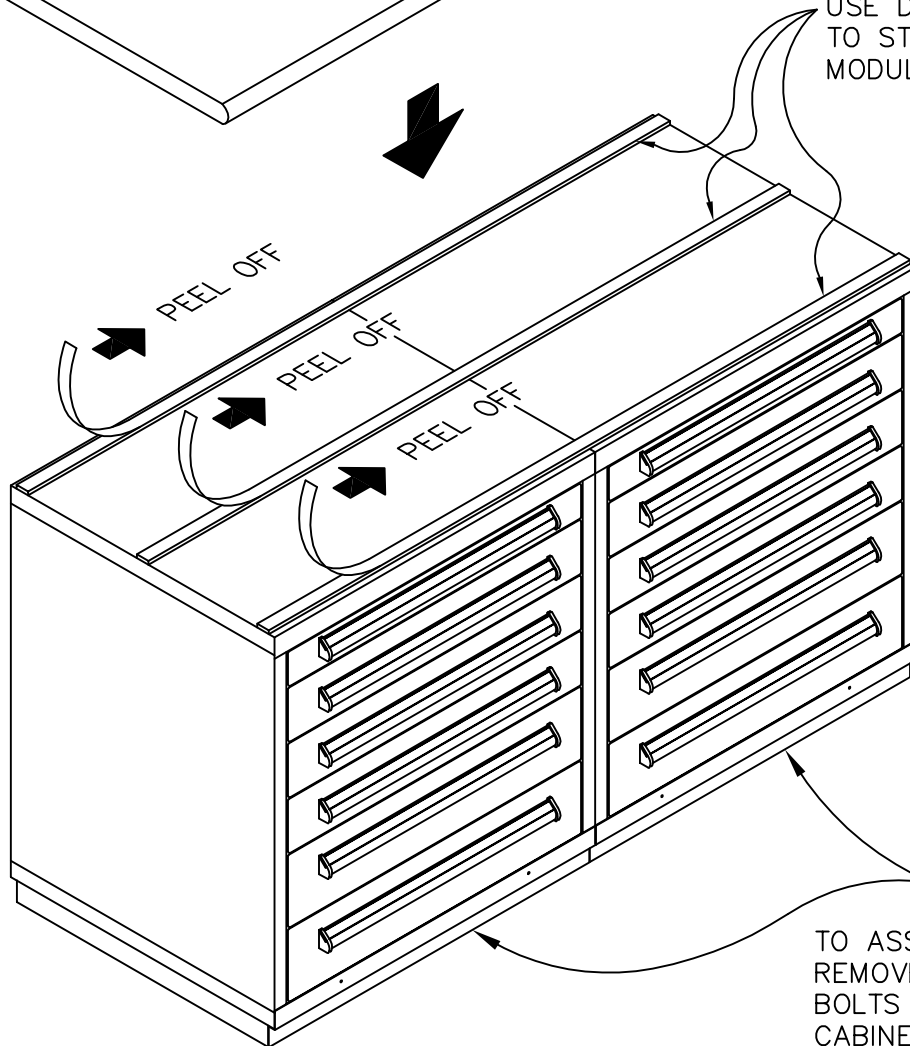

### NOTE

TO ASSEMBLE CABINETS TOGETHER: REMOVE TOP TWO DRAWERS AND INSERT BOLTS THROUGH HOLES IN SIDE OF CABINETS. HARDWARE PROVIDED BY BY OTHERS.

# B

# HINGED DOOR CABINET ASS'Y

## Step

### 1

## LOCKING HANDLE ASSEMBLY

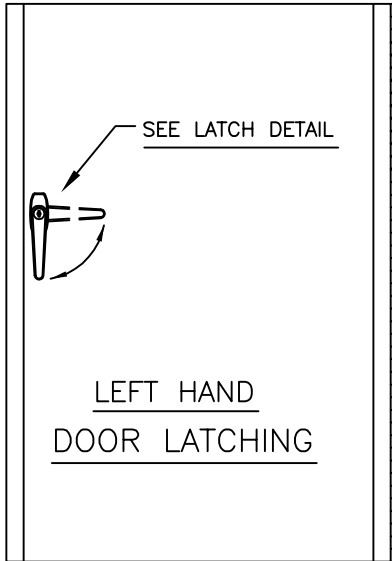

### LOCKING HANDLE ASSEMBLY PROCEDURE:

1. POSITION LOCKING HANDLE SO THAT SHANK OF LOCK PASSES THRU THE DOOR PANEL AND FASTEN SECURELY IN PLACE WITH #10-32 x 5/16 SCREWS.
2. SLIDE FLAT WASHER WITH SQUARE HOLE OVER SQUARE SHANK OF LOCK.
3. TELESCOPE #10456 LATCH PLATE OVER SHANK OF LOCK.
4. PLACE THE #13052 CUP WASHER OVER THE END OF THE SQUARE SHANK AND INSERT THE #8-32 x 3/8" SEMS SCREW. TIGHTEN SCREW SECURELY.
5. ROTATE THE HANDLE TO BE CERTAIN LATCHING MECHANISM IS OPERATING PROPERLY.

### LEFT HAND LATCH ASSEMBLY

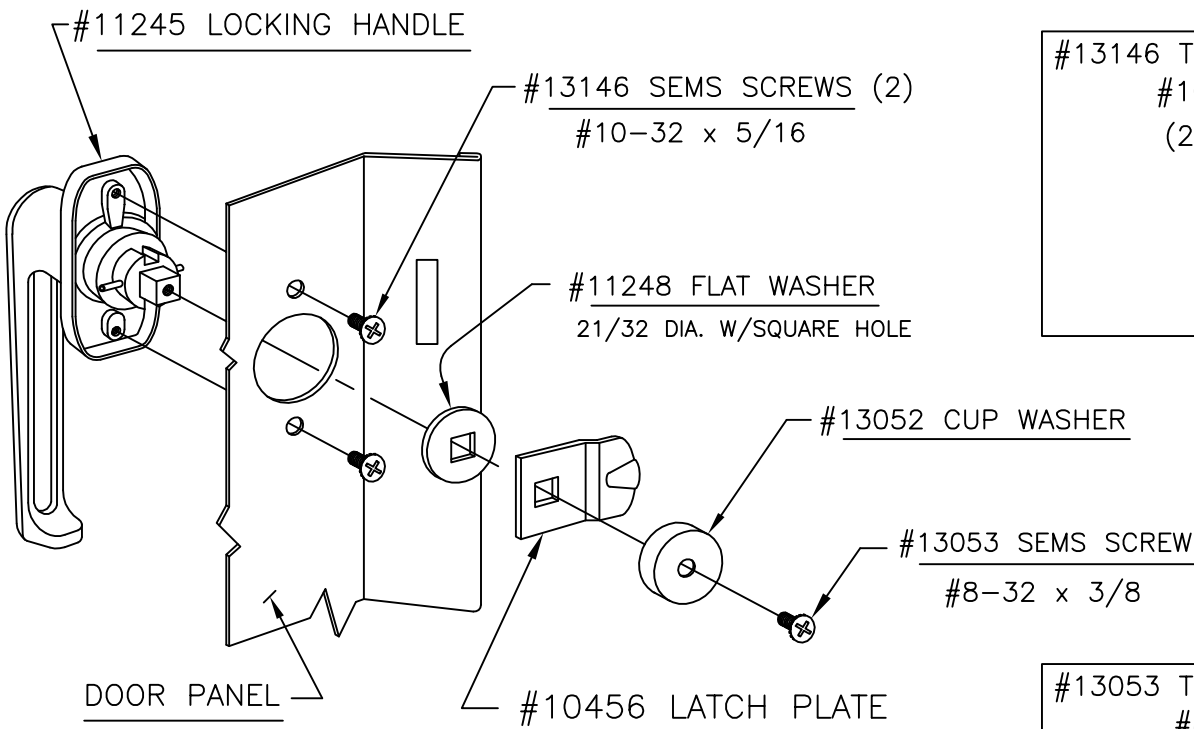

#13146 TRUSS HD MACH SCREW  
#10-32 X 5/16"  
(2 PER HANDLE)

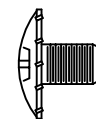

FULL SCALE

#13053 TRUSS HD MACH SCREW  
#8-32 X 3/8"  
(1 PER HANDLE)

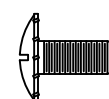

FULL SCALE

### NOTE

RIGHT AND LEFT HAND DOOR AVAILABLE.  
UNLESS OTHERWISE SPECIFIED, HANDLE  
FOR LEFT HAND DOOR HAS BEEN FURNISHED.

# Step

# 2

## HINGED DOOR ASSEMBLY

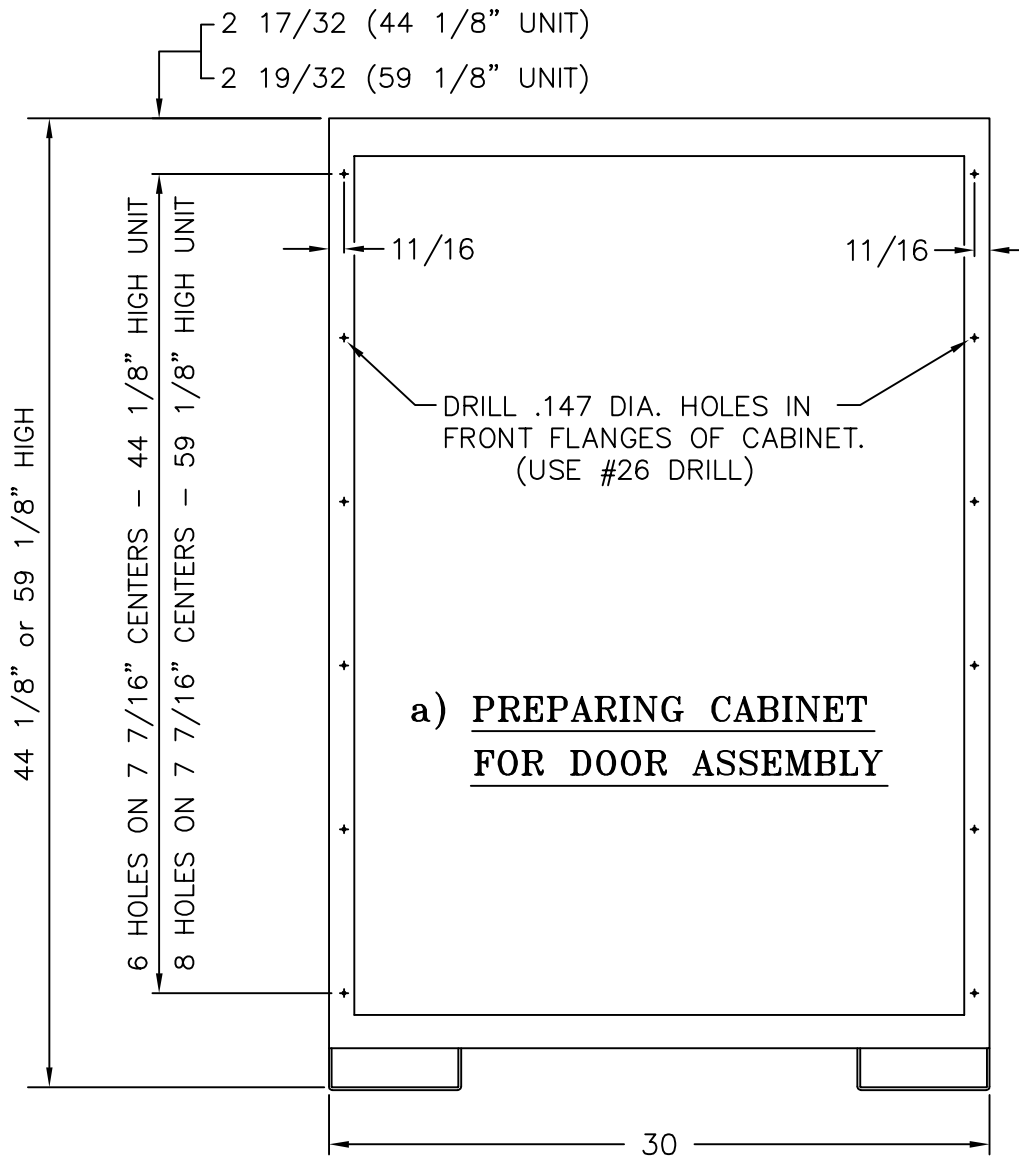

### b) HINGED CATCH AND DOOR MOUNTING

