

UNLESS OTHERWISE SPECIFIED	+ / -
Inside Form. Rad. = Matl. Thick.	
Dimensions to a Formed Edge	.03
Dimensions to a Sheared Edge	.02
Dim. Between Holes or Notches	.01
Varying Dimensions are Noted	(REF)
Angles	2°

#13125 TRUSS HD BOLTS 1/4-20 x 1-1/2

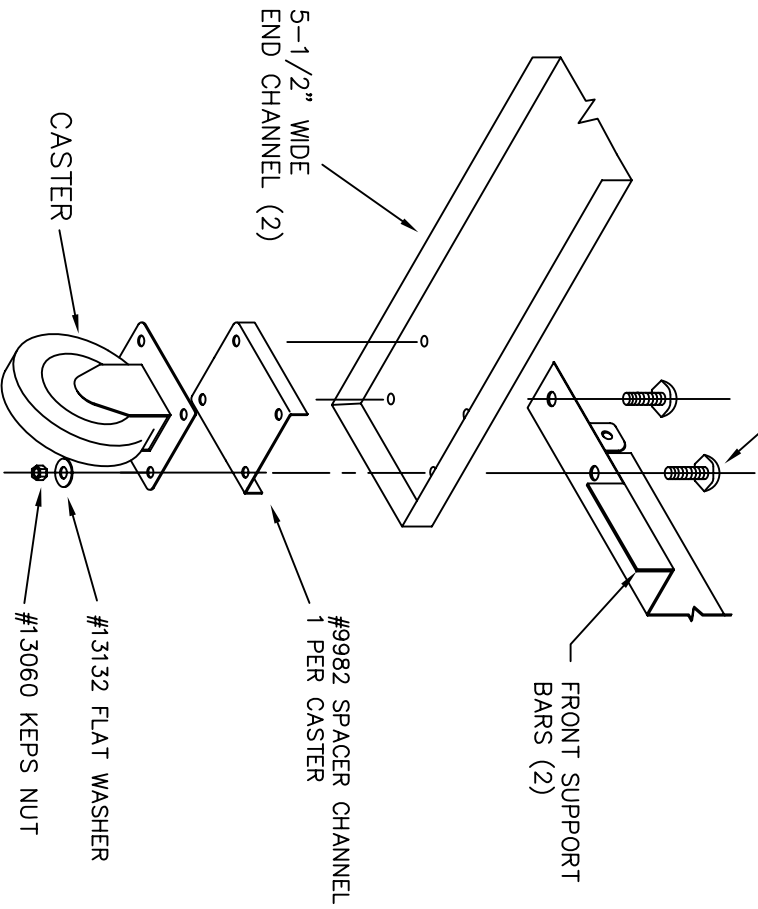

**1 ASSEMBLING BASE WITH CASTERS**

As the base is being assembled, make certain holes in the side flanges of the end channels are to the outside of the base. Be sure to install both SWIVEL CASTERS on the same end. DO NOT TIGHTEN bolts until shelving ends are in place on the base. See Detail 2.

When Macerated Casters are being used, two Shim Plates per caster should be installed.

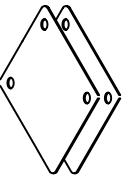

THIS DRAWING IS THE PROPERTY OF  
**EQUIPTO**  
 DALLAS, TX 75219  
 © 1998 BY EQUIPTO  
 REPRODUCTION STRICTLY FORBIDDEN

**SUPER DUTY  
 CASTER BASE  
 ASSEMBLY**

NO:	42606
SCALE:	SHEET 1 OF 1
DRWN BY: GRP	CHK BY: DCM
DISC: 0/1/4/2000	DATE: 1-31-95

REV.	DATE	DESCRIPTION OF LAST REVISION	BY	CHK BY
A	12-02-96	UPDATED TO USE CASTER CHANNEL	GRP	PD

**2 ASSEMBLED BASE WITH CASTERS WITH CASTERS INSTALLED.**

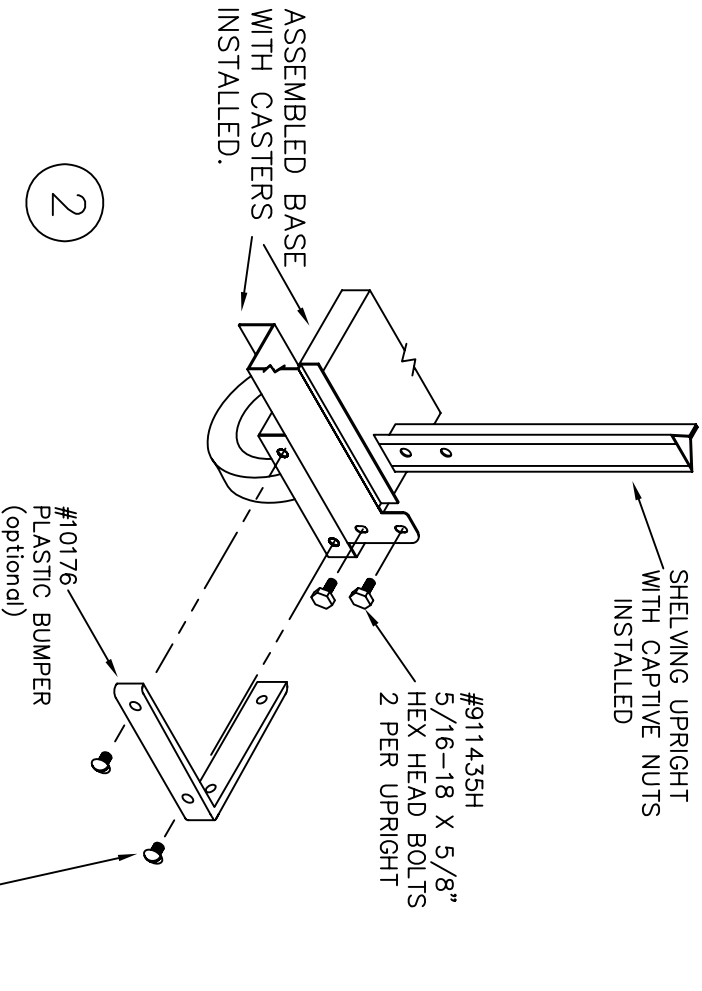

#9235 SHIM PLATES  
 2 PER CASTER  
 FOR MACERATED CASTER ONLY

#13162  
 10-24 x 1/2"  
 TRUSS HEAD  
 BOLTS WITH  
 LOCKWASHERS  
 (4 per bumper)