

41296

EQUIPTO

Tire Rack Rack Assembly
Instructions

READ INSTRUCTIONS BEFORE ASSEMBLING

TIRE RACK INSTALLATION

A. END FRAME ASSEMBLY

NOTE: INSERT BRACE PLATE BETWEEN FLANGES OF THE UPRIGHTS AND FASTEN AS SHOWN. MAKE CERTAIN SLOTS IN BOTH UPRIGHTS ARE FACING IN THE SAME DIRECTION BEFORE BOLTING.(SEE SLOT BELLOW) MAKE TWO END FRAME ASSEMBLIES. TIGHTEN SCREWS SECURELY.

NOTE: FOR SEISMIC AREAS REFERENCE SECTION D FOR FLOOR ANCHOR INSTALLATION BEFORE CONTINUING.

SLOT TOP



#13160 PHILIPS HEAD SCREW
#10-24 X 3/8"

#13061 #10-24 HEX NUT
(4 PER END BRACE)

FULL SCALE

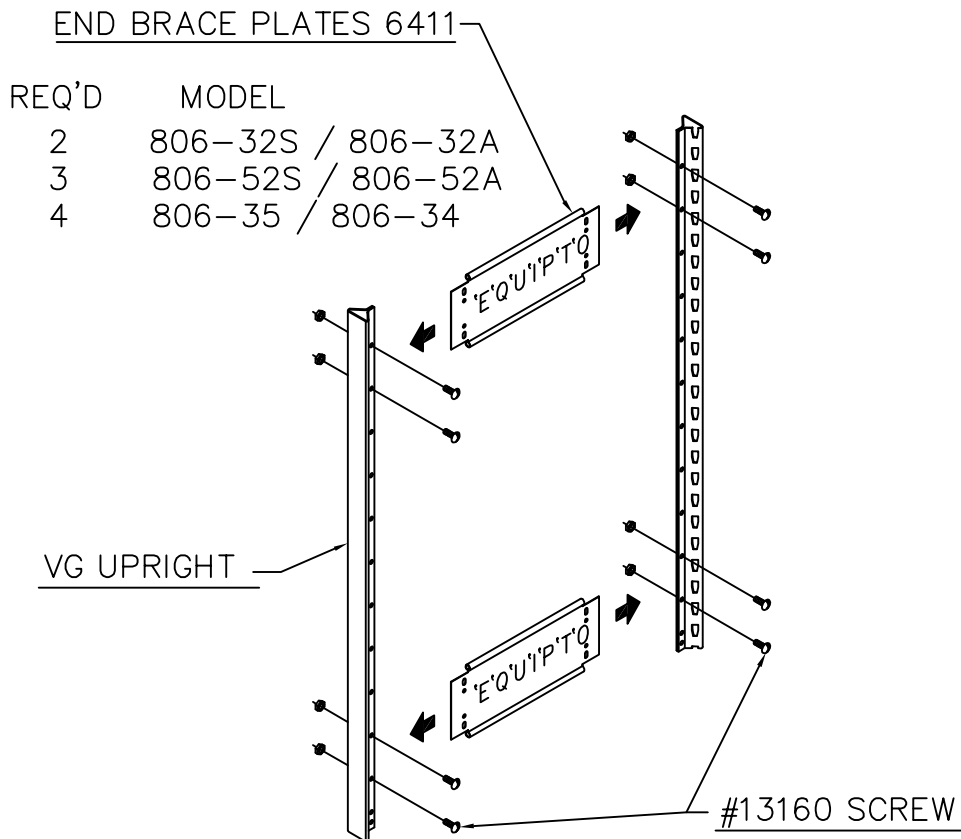

B. CROSS BEAM ASSEMBLY

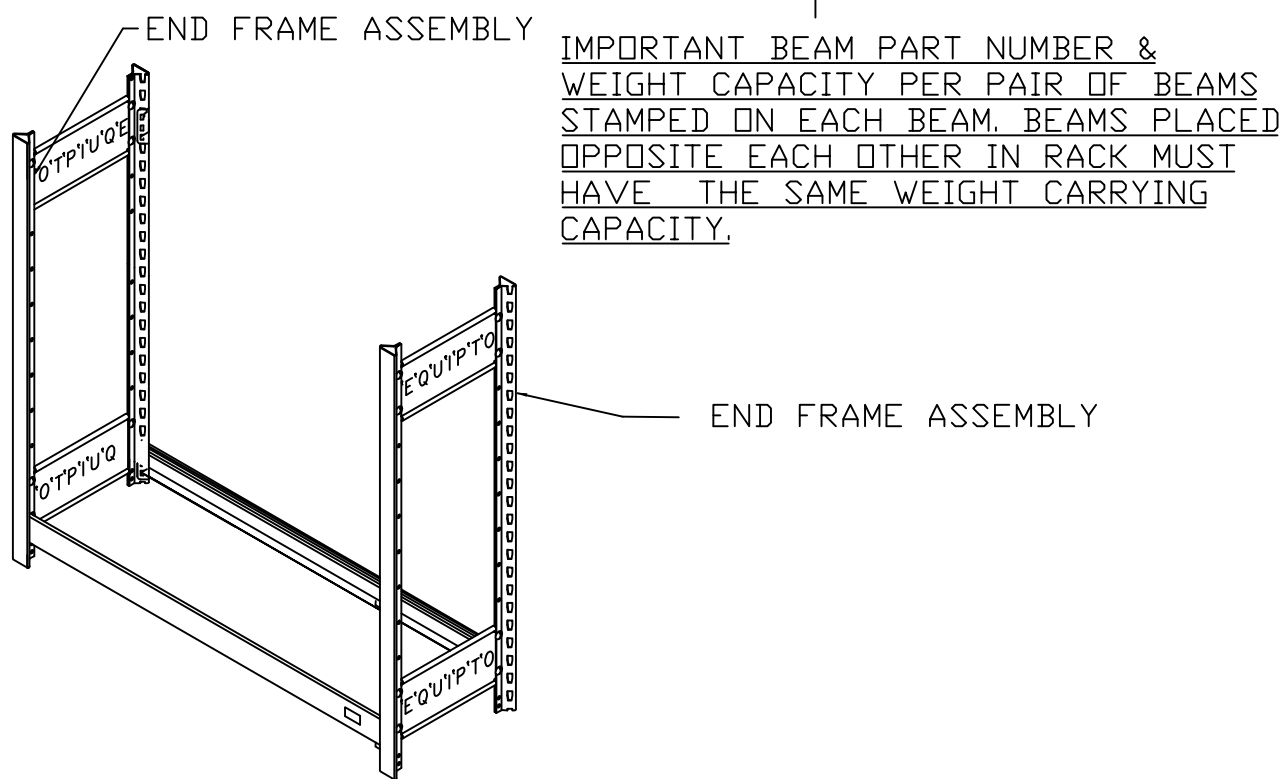
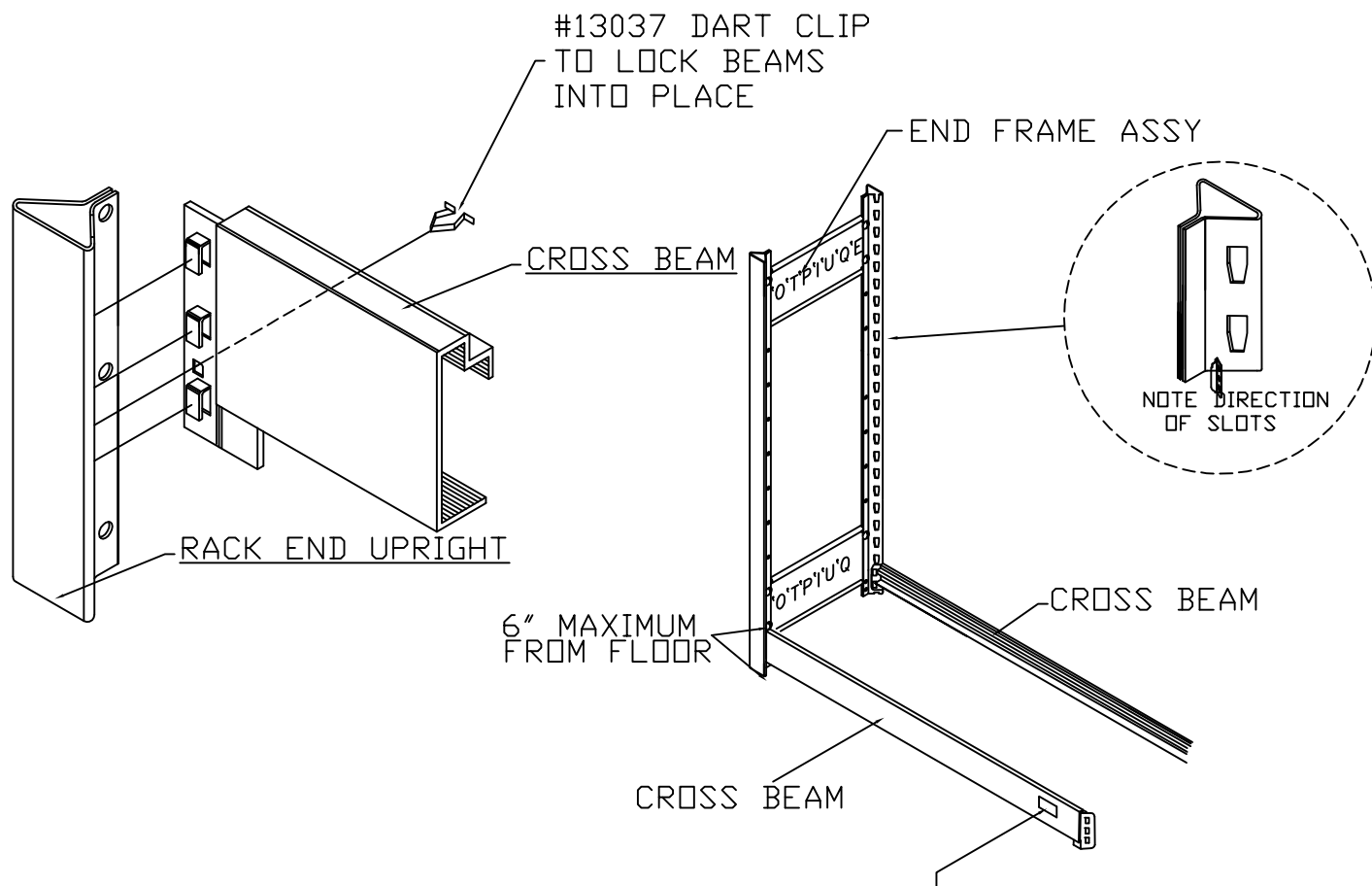

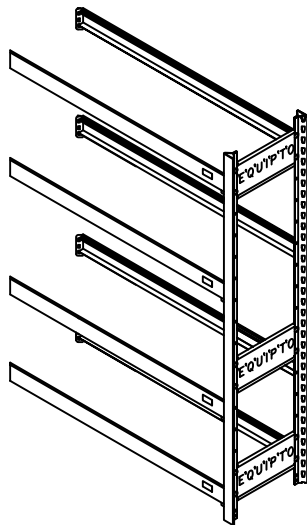
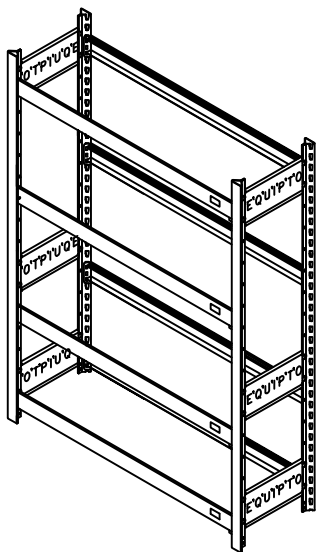

806-32S
STARTING UNIT
10'H X 5'W X
15"D

806-32A
ADD-ON UNIT
10'H X 5'W X
15"D

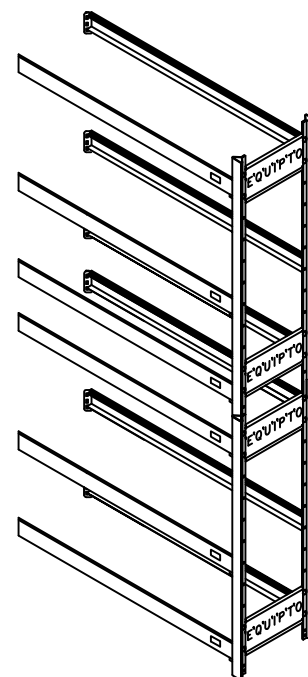
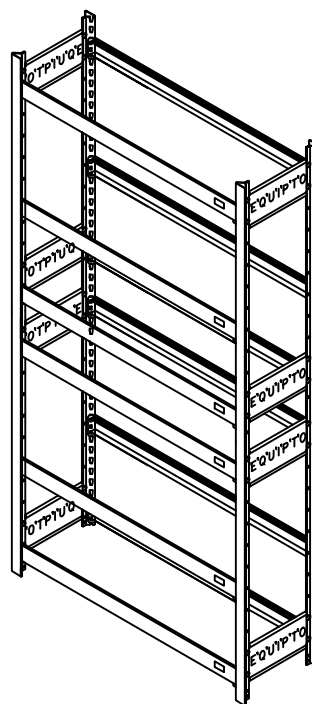

806-54
STARTING UNIT
15'H X 5'W X
15"D

806-55
ADD-ON UNIT
15'H X 5'W X
15"D

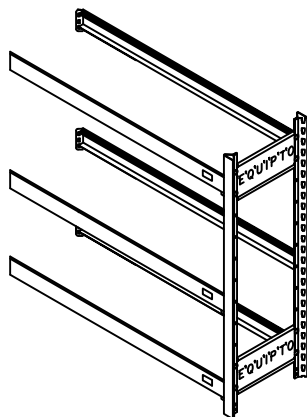
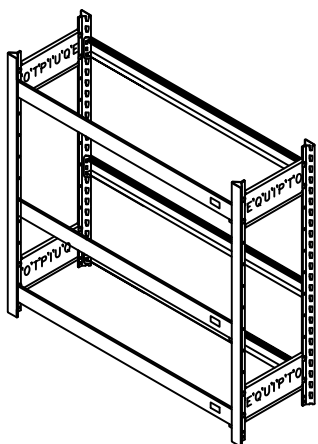

806-52S
STARTING UNIT
7'H X 5'W
X 15"D

806-52A
ADD-ON UNIT
7'H X 5'W X
15"D

C. TYPICAL FLOOR ANCHOR INSTALLATION

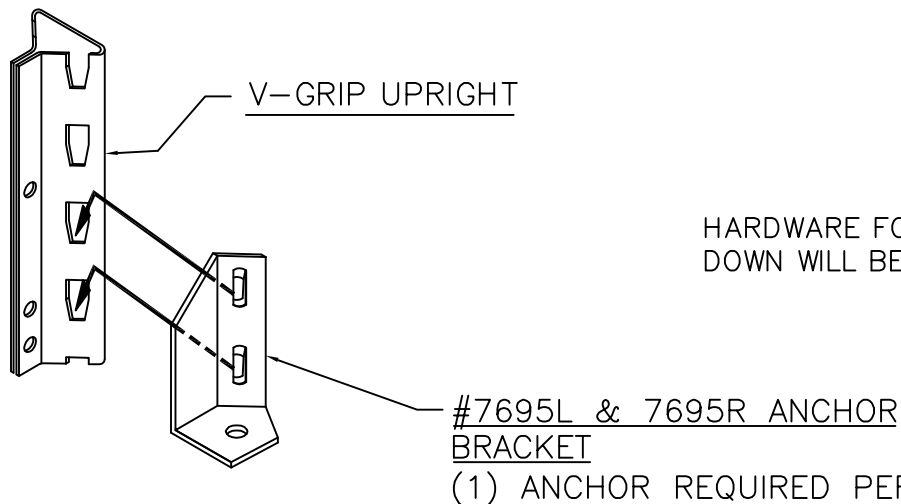

NOTE

HARDWARE FOR ANCHORING BRACKET DOWN WILL BE PROVIDED BY OTHERS.

D. SEISMIC FLOOR ANCHOR ASS'Y INSTALLATION

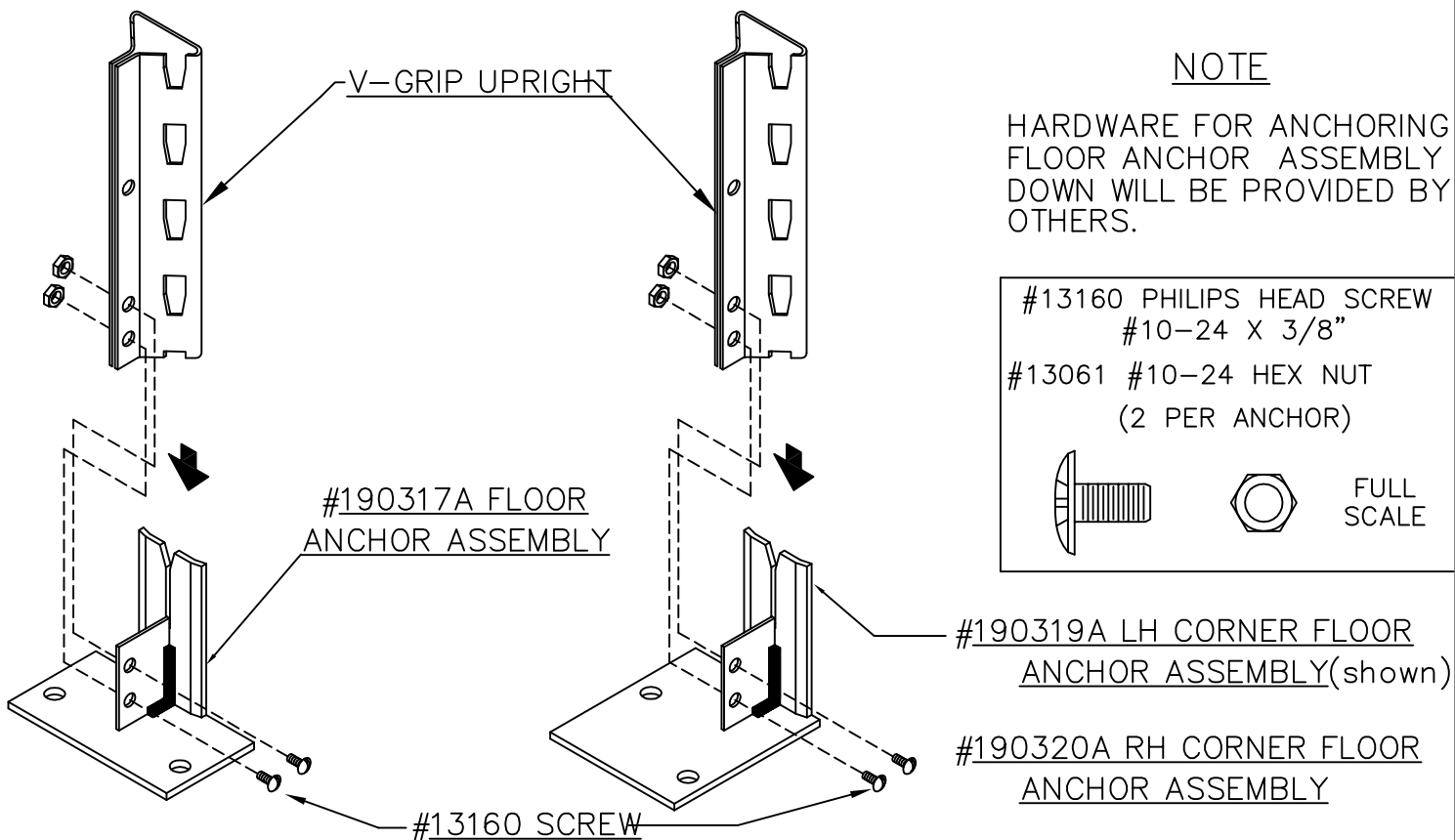

NOTE

HARDWARE FOR ANCHORING FLOOR ANCHOR ASSEMBLY DOWN WILL BE PROVIDED BY OTHERS.

#13160 PHILIPS HEAD SCREW
#10-24 X 3/8"

#13061 #10-24 HEX NUT
(2 PER ANCHOR)

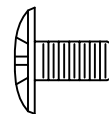

FULL SCALE

#190319A LH CORNER FLOOR ANCHOR ASSEMBLY (shown)

#190320A RH CORNER FLOOR ANCHOR ASSEMBLY

E. WALL SEPARATOR BAR ASSEMBLY

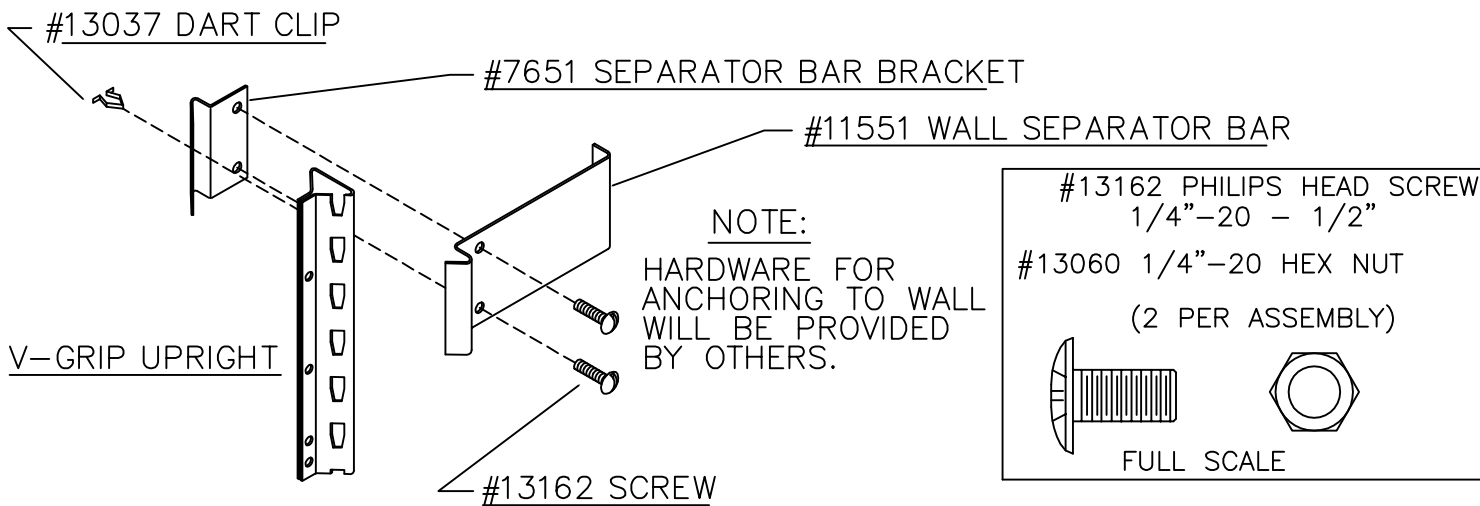

F. BACK TO BACK ASSEMBLY

