

12310ASY

EQUIPTO

SHELVING WIDE DRAWERS
Assembly Instructions

READ INSTRUCTIONS BEFORE ASSEMBLING

SHELVING WIDE DRAWERS

ASSEMBLY INSTRUCTIONS

Step

1

POST AND BRACKET ASSEMBLY

a) V-GRIP POST BRACKET

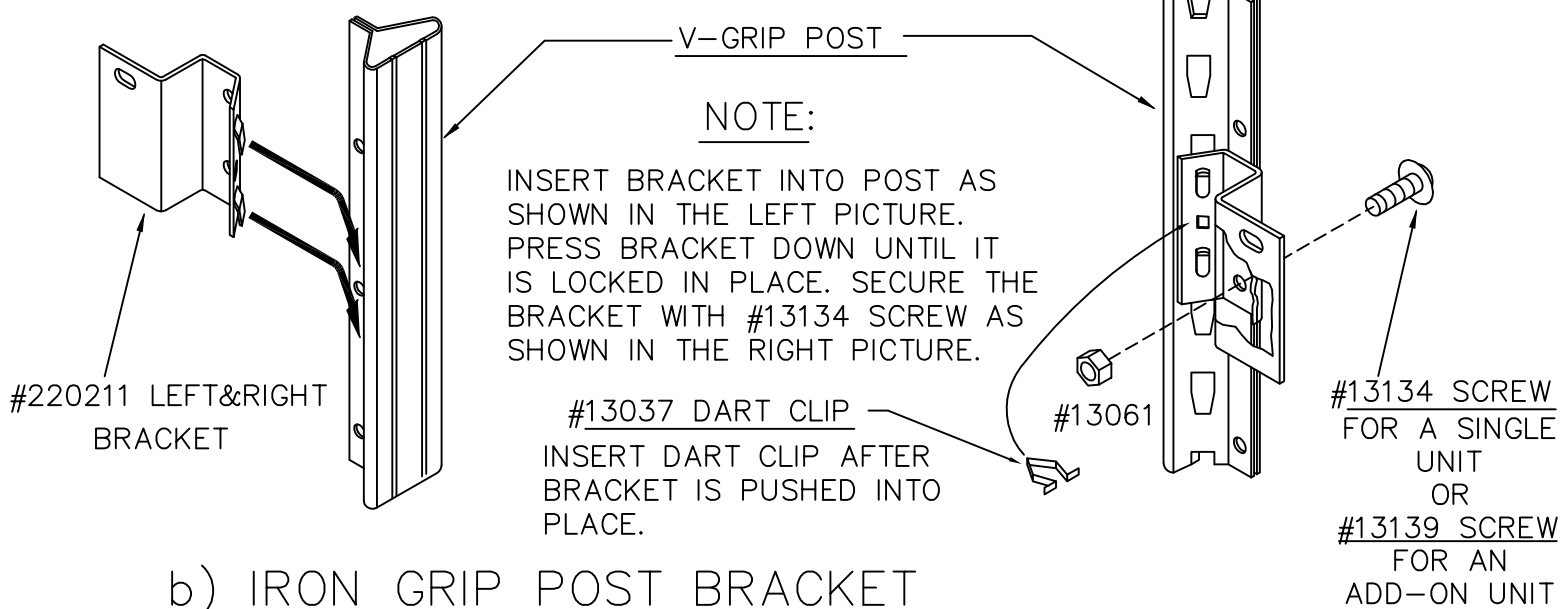

b) IRON GRIP POST BRACKET

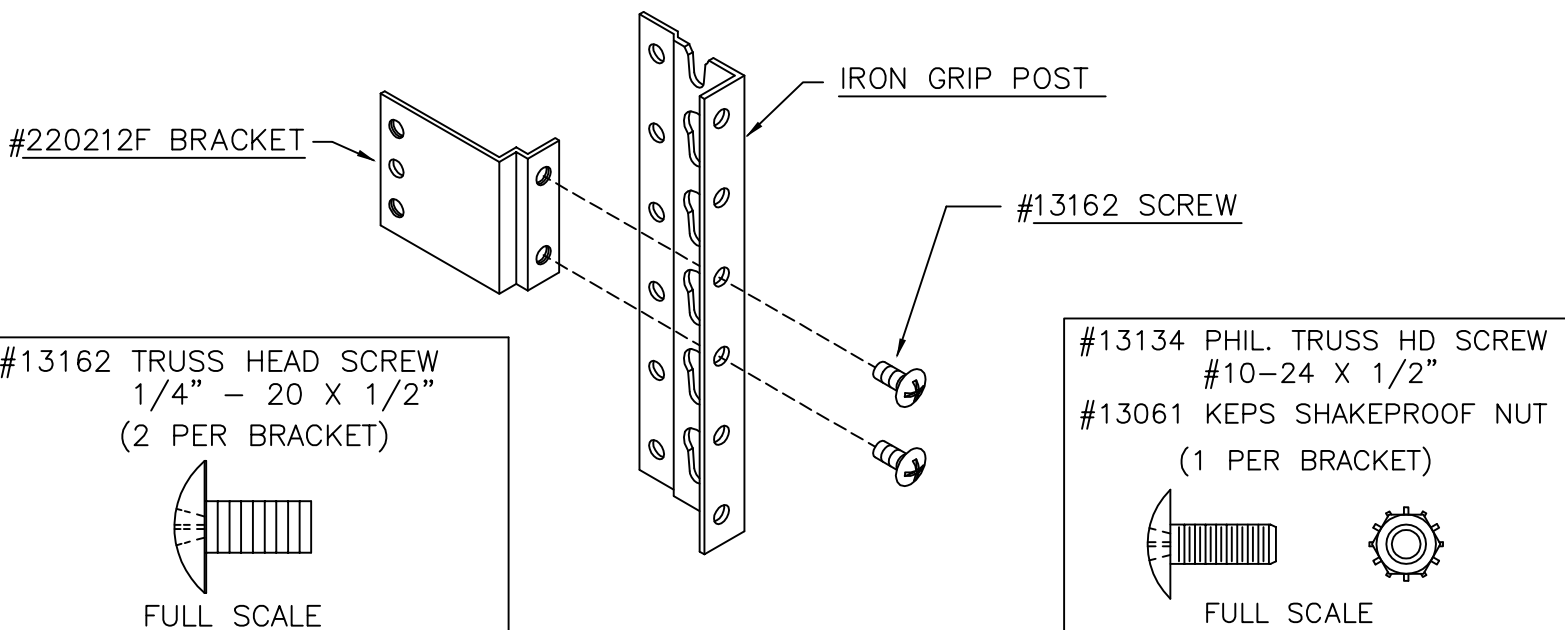

Step

2

DISASSEMBLE THE SLIDE

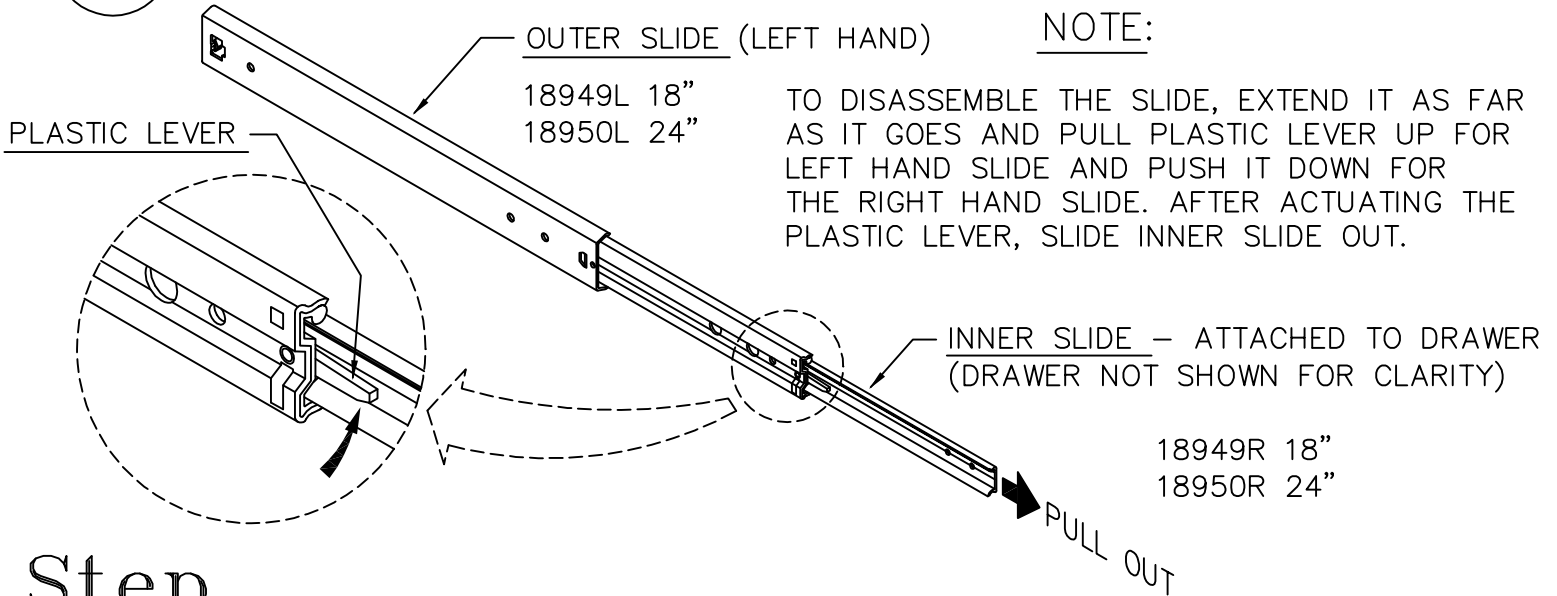

Step

3

ASSEMBLE OUTER SLIDE TO BRACKETS

a) V-GRIP ASSEMBLY

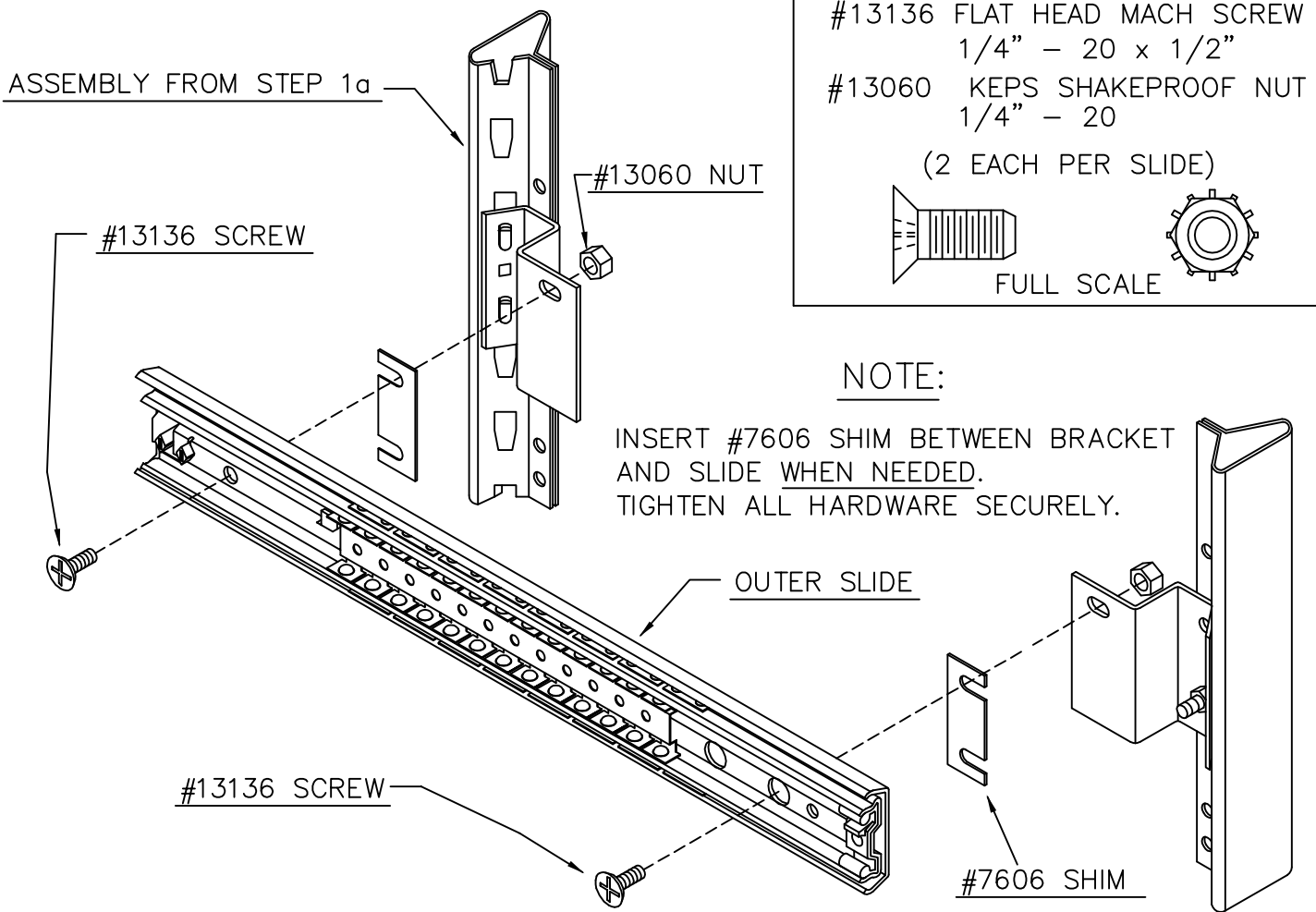

b) IRON GRIP ASSEMBLY

#13136 FLAT HEAD MACH SCREW
1/4 - 20 x 1/2
(2 PER SLIDE)

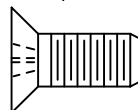

FULL SCALE

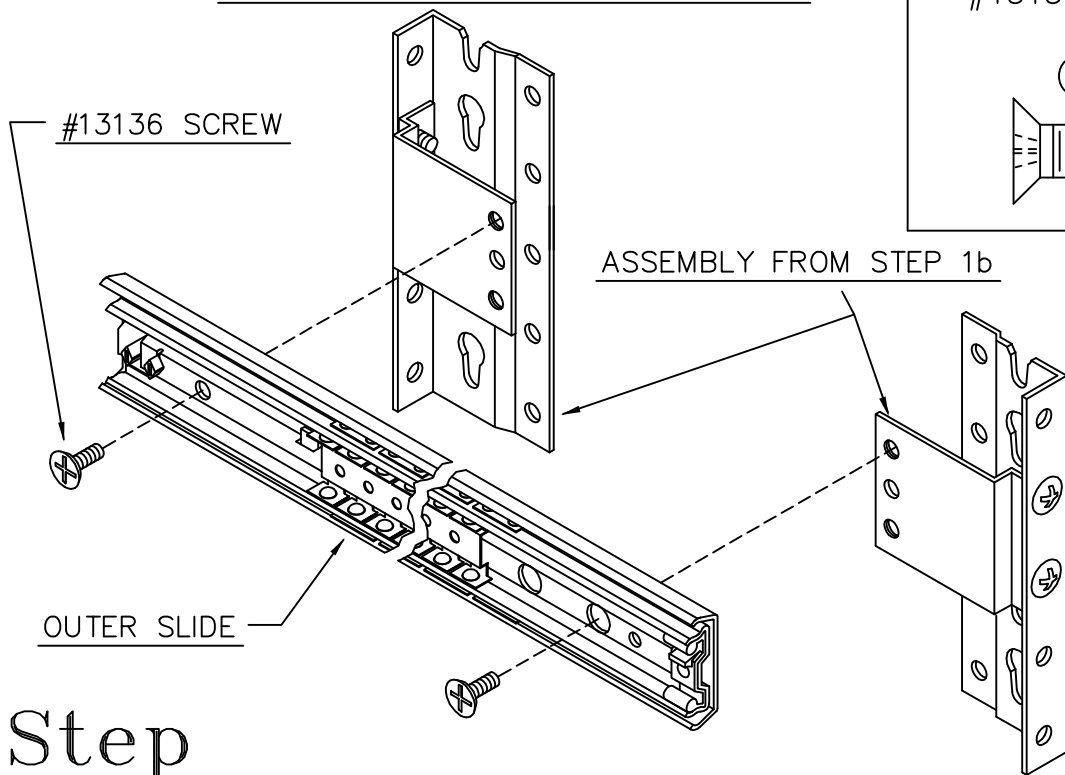

NOTE:
TIGHTEN ALL HARDWARE
SECURELY.

Step

4

DRAWER AND SLIDE ASSEMBLY

NOTE:

WHEN DRAWER IS INSERTED INTO THE
OUTER SLIDES, ADVANCE THE DRAWER
PARALLEL TO THE OUTER SLIDES TO
AVOID BINDING.

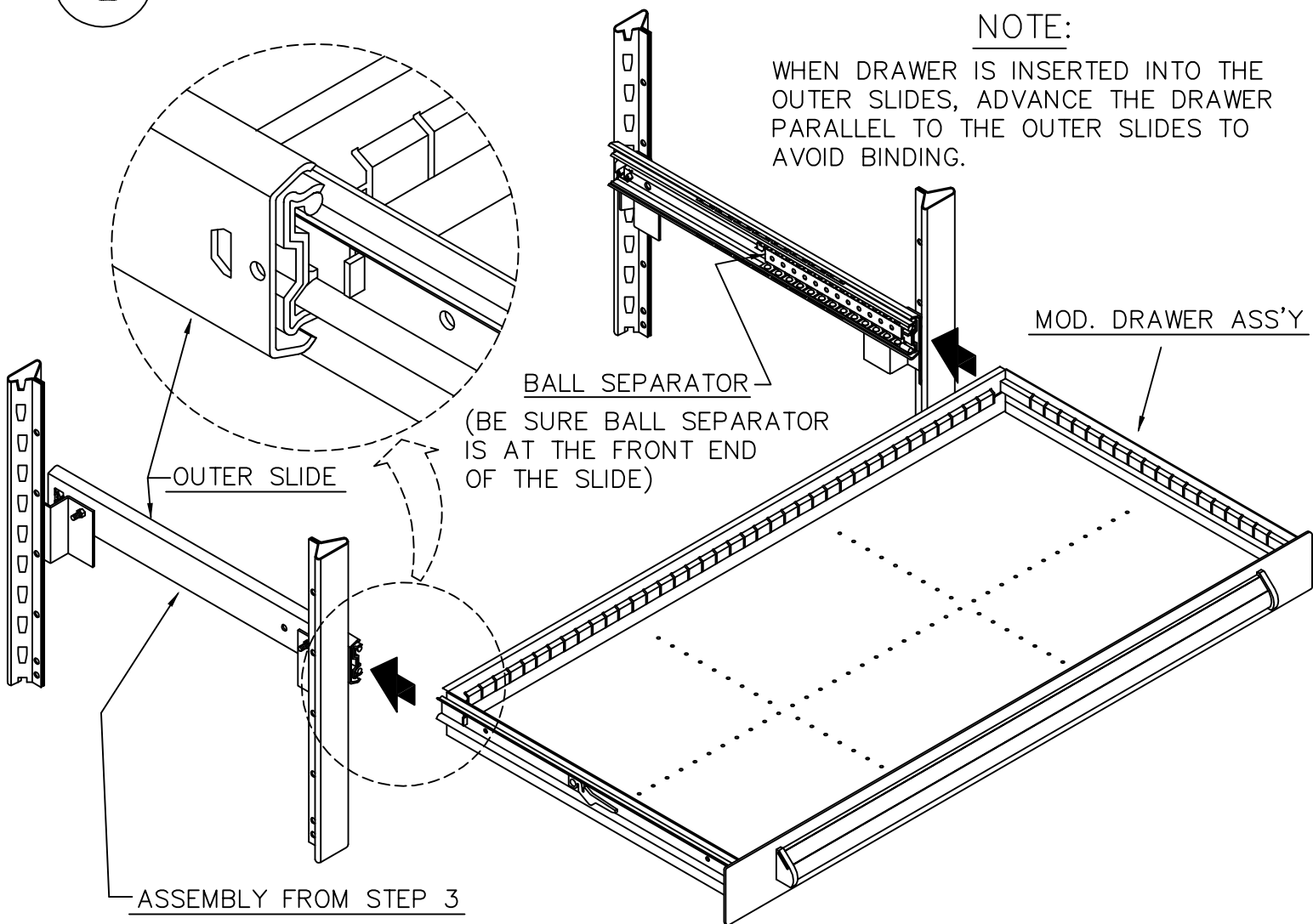

PARTITION ASSEMBLY

MODULAR CABINET DEPTH	PARTITION HEIGHT					
	FRONT TO BACK PARTITION			SIDE TO SIDE PARTITION		
	2"	3"	4 1/2"	2"	3"	4 1/2"
18" DEEP	220310F	220311F	220312F	8770	8771	8772
24" DEEP	220320F	220321F	220322F	8770	8771	8772

NOTE:

LOCATE PARTITIONS TO FIT
DIVIDERS WHEN USED.

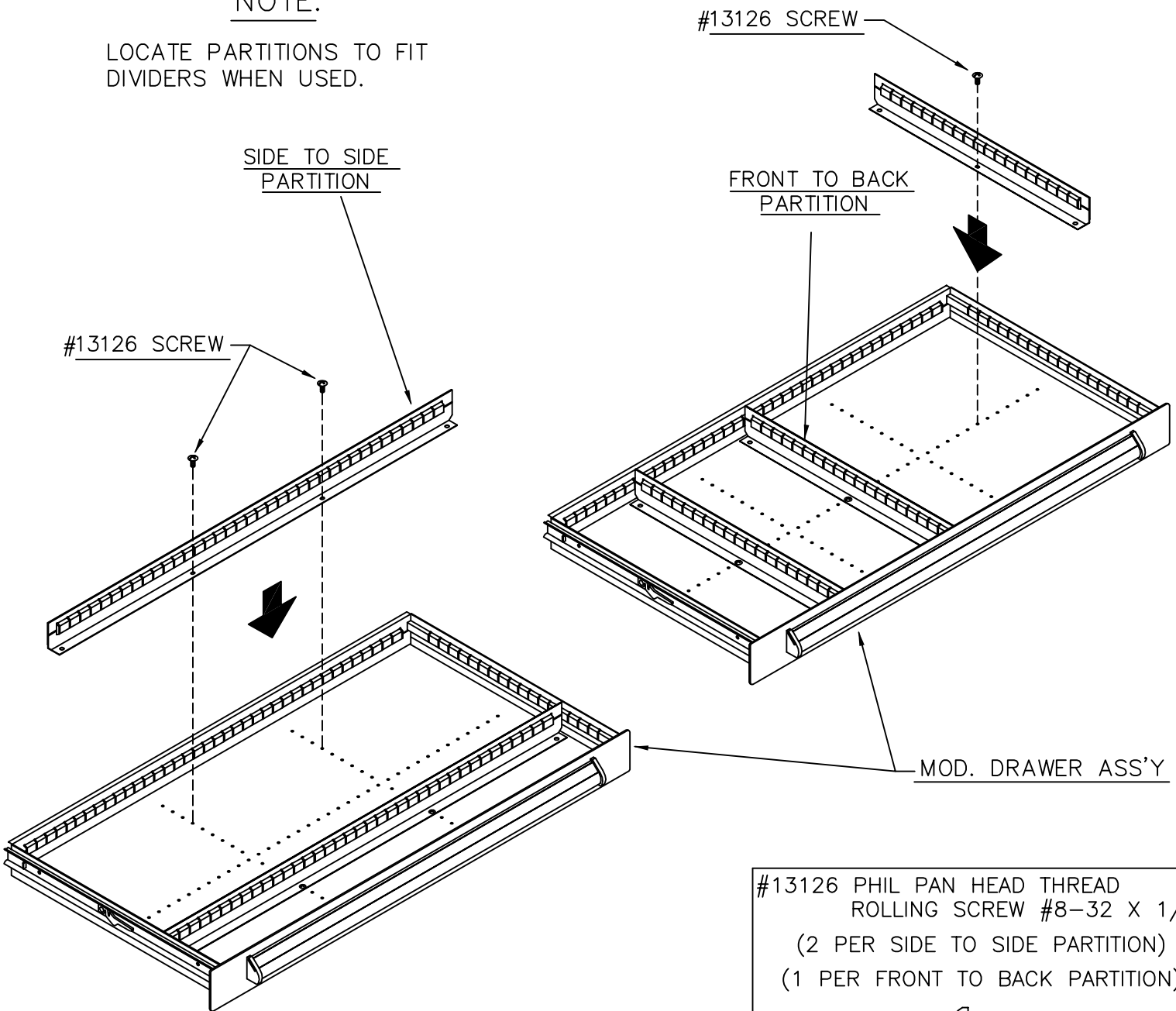

#13126 PHIL PAN HEAD THREAD
ROLLING SCREW #8-32 X 1/4"
(2 PER SIDE TO SIDE PARTITION)
(1 PER FRONT TO BACK PARTITION)



FULL SCALE