

REEL RACKS

ORGANIZE REELS OF CABLE AND SUPPLIES, MAKING THEM EASY TO RETRIEVE. EQUIPTO REEL RACKS HOLD UP TO 2000 LBS. PER LEVEL, AND UP TO 1200 LBS. PER RACK. (REEL RODS NOT INCLUDED.)

RACKS HOLD SMALL TO LARGE REELS ON BOTH SIDES – SAFELY. AND YOU CAN MOVE THEM EASILY BY HAND OR FORK LIFT TRUCK.

- HIGH CAPACITY FREE STANDING A-FRAME RACKS
- 8'-10'-12' HEIGHTS
- 12000 LB. CAPACITY
- 3" X 3" VERTICAL POSTS WITH MOUNTING HOLES
- ADJUSTABLE CROSS BEAMS ON 2" CENTERS WITH AUTOMATIC SAFETY LOCKS



1072R04



1076E08
RACK ENDS

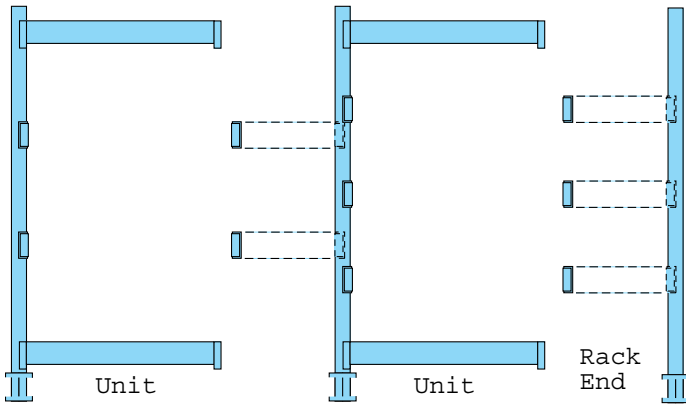

EACH UNIT SUPPLIED WITH RIGHT-HAND REEL HOLDERS (AS SPECIFIED) THAT FASTEN TO NEXT UNIT OR RACK END.

WIDTH	HEIGHT			NO. OF REEL HOLDERS
	96"	120"	144"	
48"	1072R04	1072R14	1072R24	TWO PAIR
72"	1072R06	1072R16	1072R26	TWO PAIR
48"	1073R04	1073R14	1073R24	THREE PAIR
72"	1073R06	1073R16	1073R26	THREE PAIR
48"	1074R04	1074R14	1074R24	FOUR PAIR
72"	1074R06	1074R16	1074R26	FOUR PAIR
48"	1075R04	1075R14	1075R24	FIVE PAIR
72"	1075R06	1075R16	1075R26	FIVE PAIR

1076E08 RACK END, 96" HIGH
 1076E10 RACK END, 120" HIGH
 1076E12 RACK END, 144" HIGH

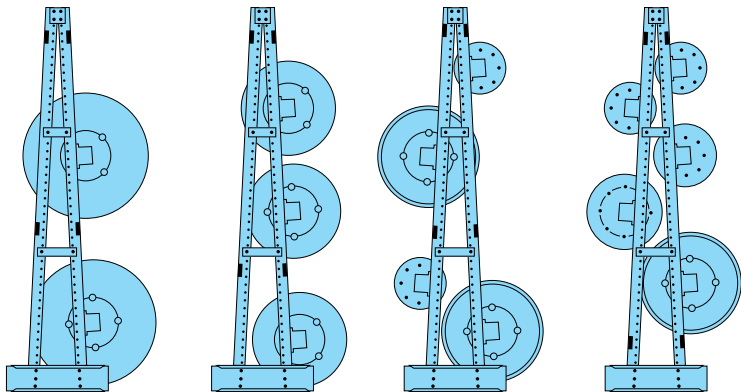

RACK WITH TWO PR. REEL HOLDERS

RACK WITH THREE PR. REEL HOLDERS

RACK WITH FOUR PR. REEL HOLDERS

RACK WITH FIVE PR. REEL HOLDERS

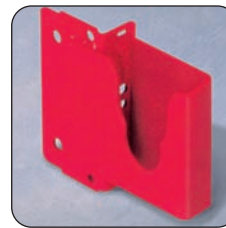

EXTRA REEL HOLDERS

- PAIRS ONLY.
- REEL HOLDERS ACCOMMODATE AXLES UP TO 2^{3/8}" O.D.

SHAFT SIZE	CAPACITY	CATALOG No. (PR.)
To 2 ^{3/8} " O.D.	2000 LBS.	78218RH

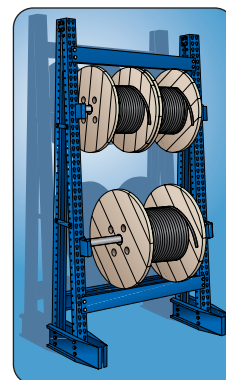

PIPE NOT INCLUDED. SECURE STANDARD SCHEDULE 40 PIPE (UP TO 2" NOMINAL) FROM YOUR LOCAL PLUMBING SUPPLY. USE 47" PIPE LENGTH FOR 48" WIDE RACK; 71" PIPE FOR 72" WIDE RACK. REEL HOLDERS ARE ADJUSTABLE ON 2" INCREMENTS TO HOLD MULTIPLE REELS.

STANDARD COLOR - OFFICE GRAY. COLOR COORDINATING? REFER TO EQUIPTO COLOR CHART - INSIDE REAR COVER.