

216ASY

EQUIPTO

OSHA 'F' – SERIES STAIRWAY ASSEMBLY INSTRUCTIONS

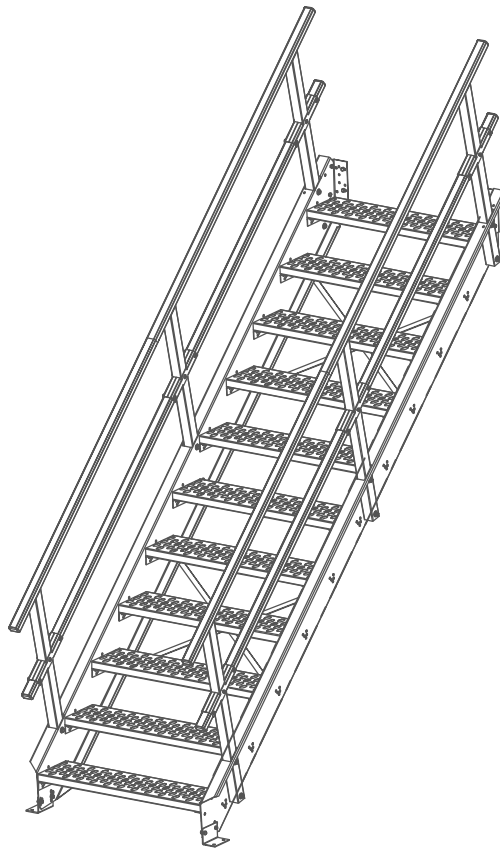

TABLE OF CONTENTS

STAIRWAY ASSEMBLY

- 1. TOP ANGLE ASSEMBLY PAGE 3
 - 1a. MOUNTING TOP ANGLE TO BUILDING STRUCTURE PAGE 3
 - 1b. MOUNTING TOP ANGLE TO V-GRIP UPRIGHT PAGE 3
 - 1c. MOUNTING TOP ANGLE TO IRON GRIP UPRIGHT PAGE 3
 - 1d. MOUNTING TOP ANGLE TO SLOTTED ANGLE. PAGE 4
 - 1e. MOUNTING TOP ANGLE TO GRATING. PAGE 4
- 2. RISER PANEL ASSEMBLY. PAGE 5
 - 2a. ASSEMBLE RISER PANEL TO TOP ANGLE. PAGE 5
 - 2b. ASSEMBLE RISER PANEL TO FLOOR ANGLE. PAGE 5
- 3. STAIR TREAD ASSEMBLY. PAGE 6
 - 3a. STAIR TREAD AND SUPPORT ANGLE ASSEMBLY. PAGE 6
 - 3b. FASTENING STAIR TREAD ASSEMBLY TO RISER PAGE 6
- 4. SWAY BRACE ASSEMBLY. PAGE 7

STAIR RAILING ASSEMBLY

- 1. RAILING POST ASSEMBLY PAGE 8
- 2. TOP HAND RAIL ASSEMBLY. PAGE 8
 - 2a. FOR F04 THROUGH F10 STAIRWAYS. PAGE 8
 - 2b. FOR F11 THROUGH F12 STAIRWAYS. PAGE 10
 - 2c. FOR F14 THROUGH F17 STAIRWAYS. PAGE 12
- 3. BOTTOM AND END RAILS ASSEMBLY. PAGE 14
 - 3a. FOR F04 THROUGH F07 STAIRWAYS. PAGE 14
 - 3b. FOR F08 THROUGH F17 STAIRWAYS PAGE 15
- 4. RAILING PLUG, POST PLUG AND SLOT COVER ASY. PAGE 16

STAIR RAILING CHART

- 1. F04 THROUGH F10 PAGE 18
- 2. F11 THROUGH F12 PAGE 19
- 3. F14 THROUGH F17 PAGE 20

STAIRWAY ASSEMBLY

1 TOP ANGLE ASSEMBLY

1a) MOUNTING TOP ANGLE TO BUILDING STRUCTURE

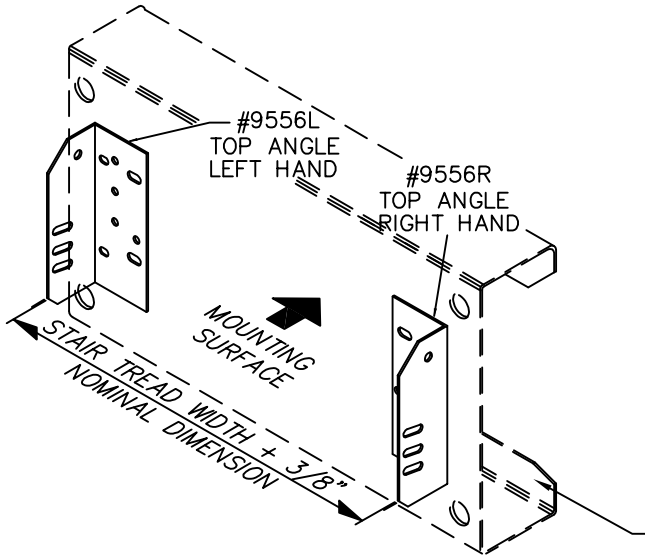

NOTE

IF MOUNTING TO BUILDING STRUCTURE, REAR SURFACE OF ANGLE MUST BE IN A PERPENDICULAR LINE, FLUSH WITH THE OUTER EDGE OF MEZZANINE PLATFORM TO GAIN FULL ADVANTAGE OF THE TOP STAIR TREAD DEPTH. A MINIMUM OF (2) FASTENERS MUST BE INSTALLED IN EACH ANGLE. IF ANGLE IS TO BE FASTENED TO THE WALL, ANCHORS MUST BE FURNISHED BY OTHERS. DO NOT TIGHTEN FASTENERS UNTIL STAIRWAY IS COMPLETELY ASSEMBLED.

TO MOUNT STAIRWAY TO EQUIPTO MEZZANINE SEE MEZZANINE INSTRUCTIONS.

1b) MOUNTING TOP ANGLE TO V-GRIP UPRIGHT

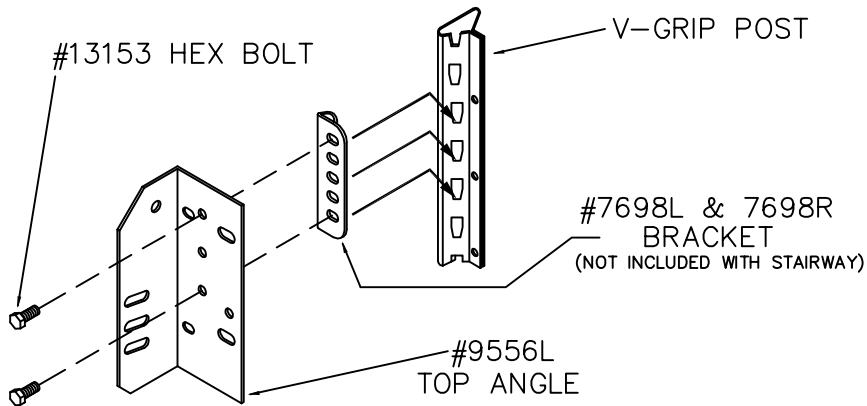

#13153 HEX BOLT 5/16-18 x 3/4"
 #13051 LOCK NUT 5/16-18
 #13182 SPRING LOCKWASHER 3/8"
 (2 PER ANGLE)

FULL SCALE

1c) MOUNTING TOP ANGLE TO IRON GRIP UPRIGHT

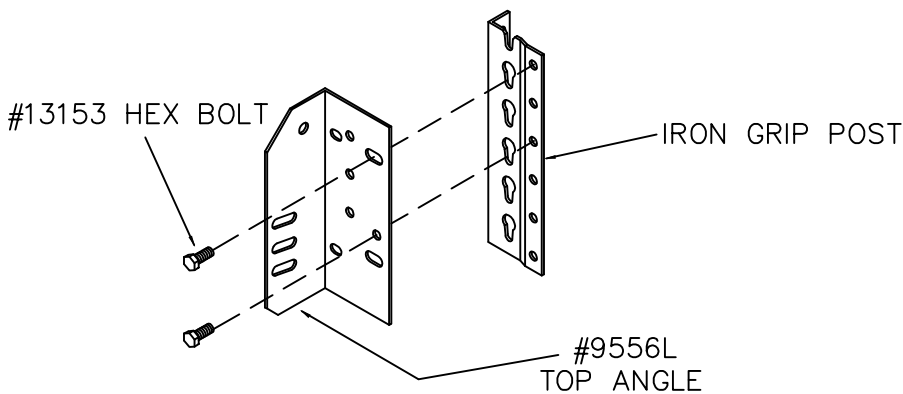

#13153 HEX BOLT 5/16-18 x 3/4"
 #13051 LOCK NUT 5/16-18
 #13182 SPRING LOCKWASHER 3/8"
 (2 PER ANGLE)

FULL SCALE

1d) MOUNTING TOP ANGLE TO SLOTTED ANGLE

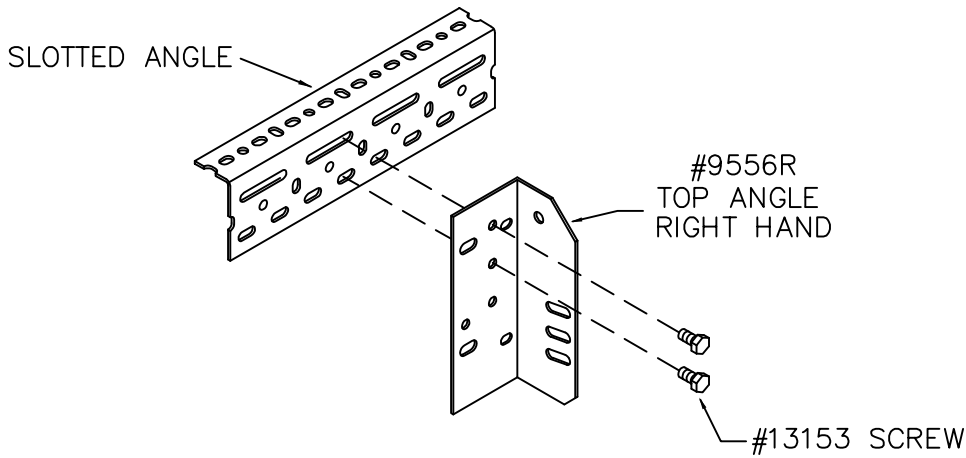

#13153 HEX BOLT 5/16-18 x 3/4"
 #13051 LOCK NUT 5/16-18
 #13182 SPRING LOCKWASHER 3/8"
 (2 PER ANGLE)

FULL SCALE

1e) MOUNTING TOP ANGLE TO GRATING
ASSEMBLE HANGER BRACKET TO GRATING PANEL
 (HARDWARE AND HANGER BRACKETS NOT INCLUDED WITH STAIRWAY)

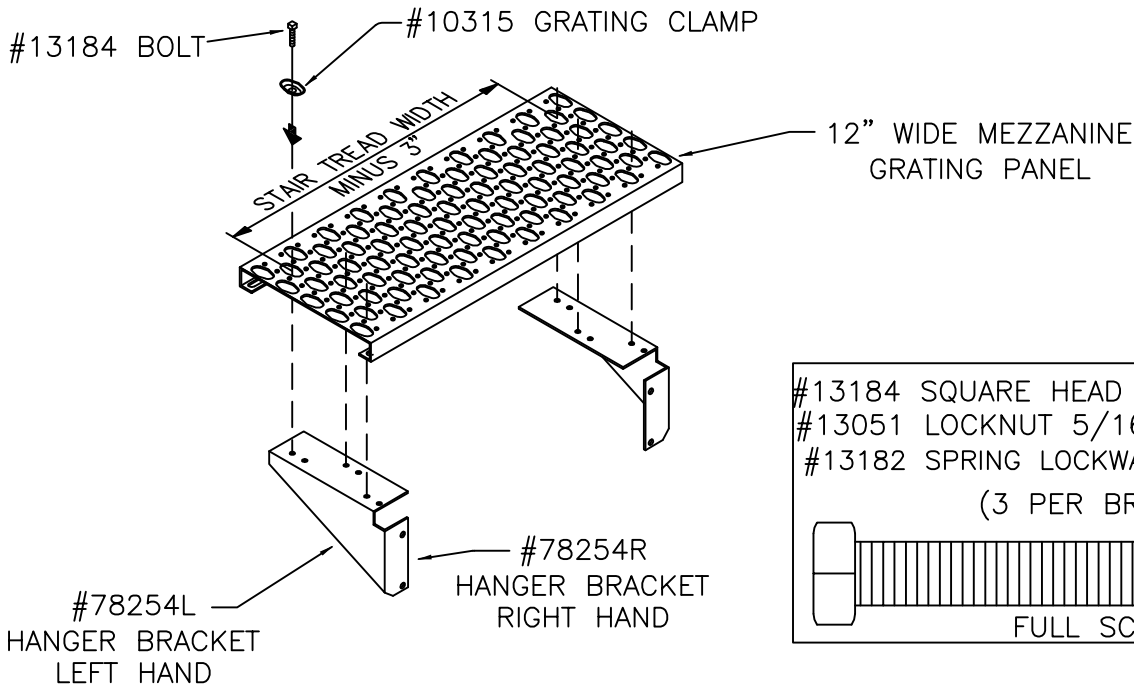

#13184 SQUARE HEAD BOLT 5/16"-18 x 2"
 #13051 LOCKNUT 5/16"-18
 #13182 SPRING LOCKWASHER 3/8"
 (3 PER BRACKET)

FULL SCALE

ASSEMBLE TOP ANGLE TO HANGER BRACKET

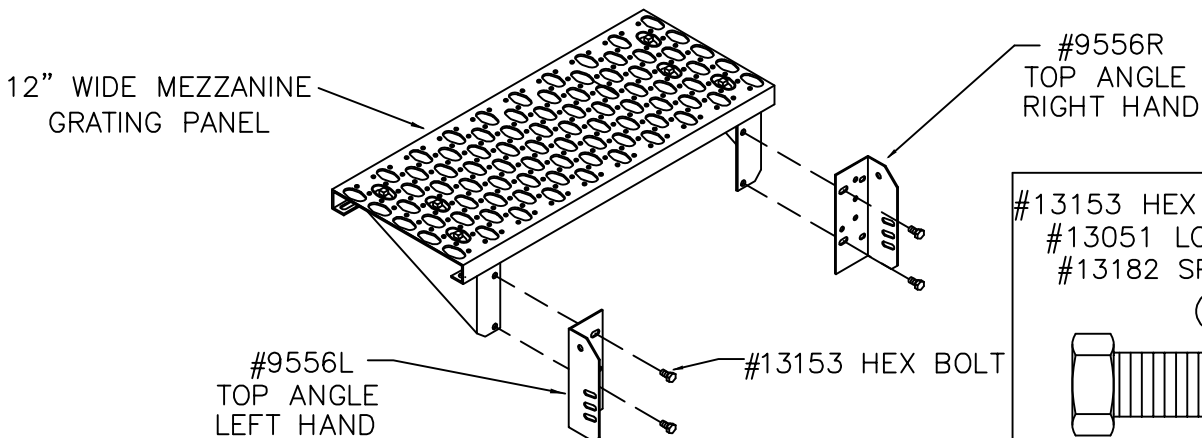

#13153 HEX BOLT 5/16-18 x 3/4"
 #13051 LOCK NUT 5/16-18
 #13182 SPRING LOCKWASHER 3/8"
 (2 PER ANGLE)

FULL SCALE

2 RISER PANEL ASSEMBLY

2a) ASSEMBLE RISER PANEL TO TOP ANGLE

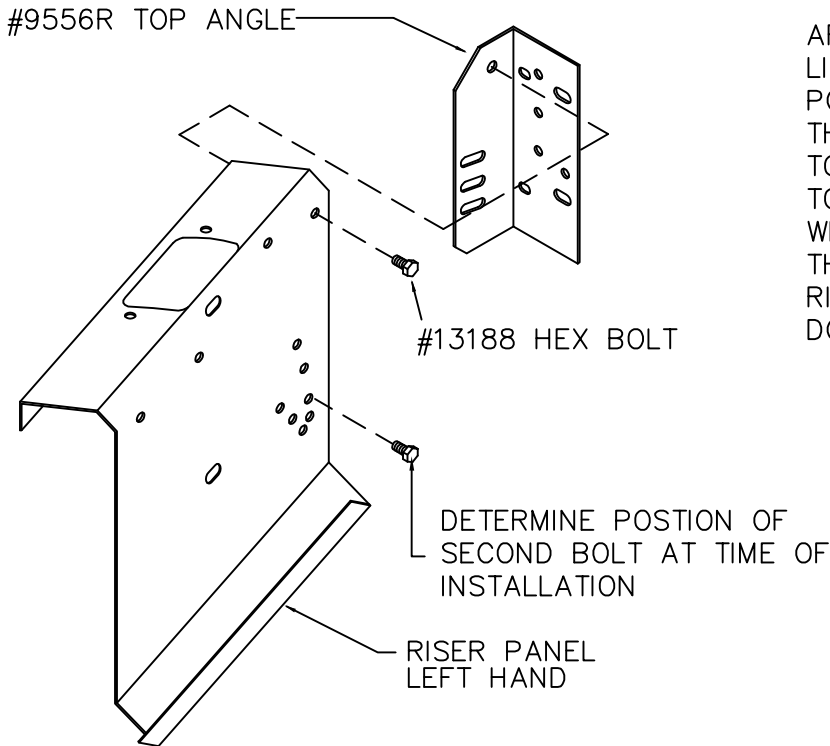

NOTE

AFTER THE TOP ANGLES ARE IN PLACE, LIFT TOP END OF THE RISER PANEL INTO POSITION WITH THE VERTICAL SURFACE OF THE RISER PANEL TO THE INSIDE OF THE TOP ANGLE AND THE SLOTTED TOP FLANGE TO THE OUTSIDE. REPEAT THIS PROCEDURE WITH THE OPPOSITE RISER PANEL. DURING THIS ASSEMBLY THE BOTTOM ENDS OF THE RISERS ARE TO REST ON THE FLOOR. DO NOT TIGHTEN BOLTS AT THIS POINT.

- #13188 HEX HEAD BOLT 3/8"-16 x 3/4"
- #13191 HEX NUT 3/8"-16
- #13182 SPRING LOCKWASHER 3/8"

(2 PER TOP ANGLE)

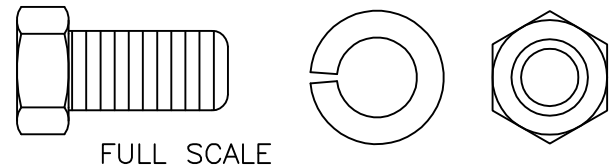

2b) MOUNTING RISER PANEL TO FLOOR ANGLE

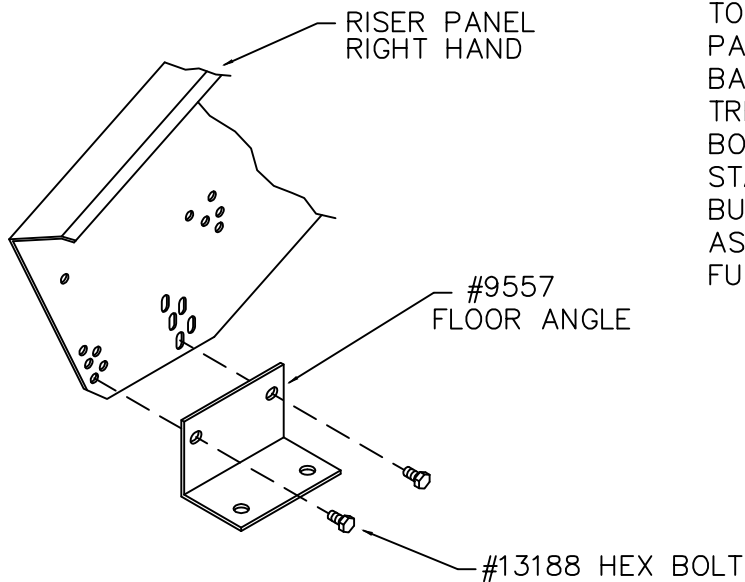

NOTE

WITH THE RISER PANEL FASTENED TO THE TOP ANGLE, RAISE LOWER END OF THE RISER PANEL FROM THE FLOOR AND FASTEN THE BASE ANGLE IN PLACE. AFTER INSTALLING STAIR TREADS MOVE BOLTS IN RISER PANEL TO MAKE BOTTOM STEP EQUAL TO OTHER STEPS. STAIRWAY IS TO BE ANCHORED TO THE FLOOR BUT NOT UNTIL STAIRWAY IS COMPLETELY ASSEMBLED. FLOOR ANCHORS ARE TO BE FURNISHED BY OTHERS.

- #13188 HEX HEAD BOLT 3/8"-16 x 3/4"
- #13191 HEX NUT 3/8"-16
- #13182 SPRING LOCKWASHER 3/8"

(2 PER FLOOR ANGLE)

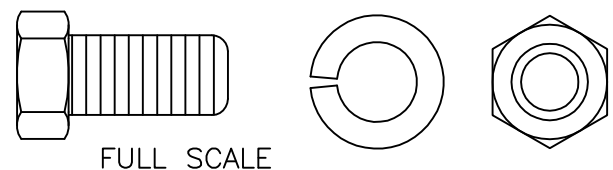

3 STAIR TREAD ASSEMBLY

3a) STAIR TREAD AND SUPPORT ANGLE ASSEMBLY

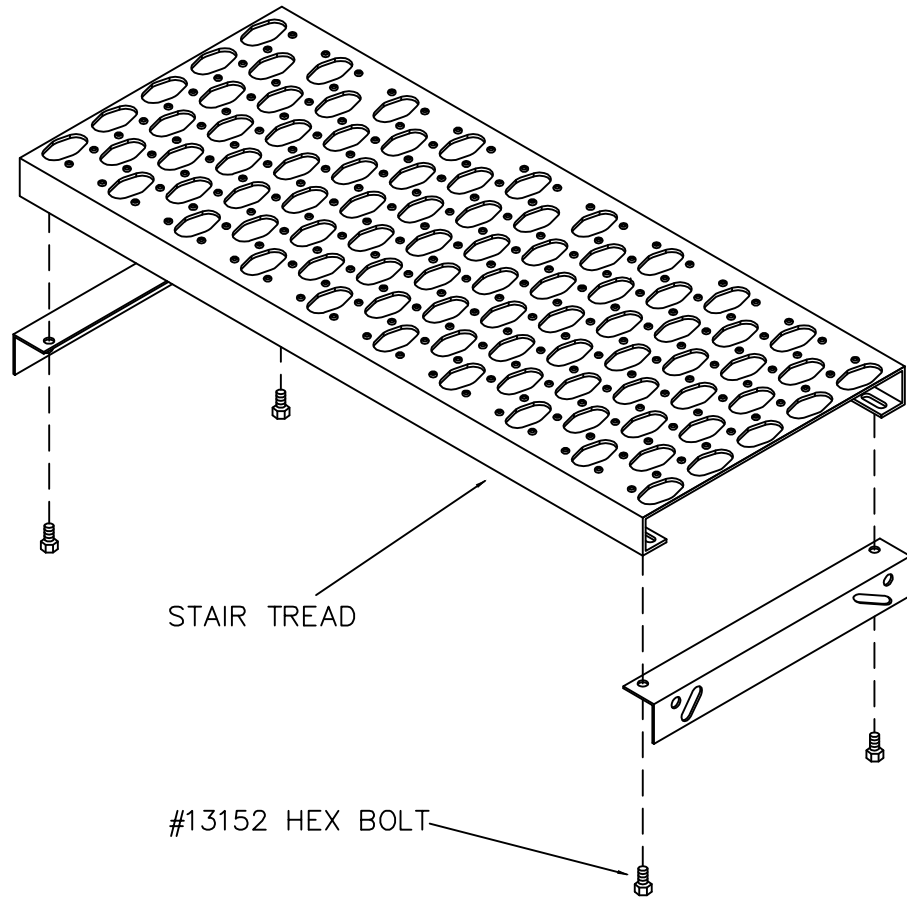

#13152 HEX BOLT
5/16" -18 X 5/8"
#13051 LOCKNUT 5/16
(2 PER ANGLE)

FULL SCALE

TREAD SUPPORT ANGLE
#9555 - 9" TREAD

NOTE
TIGHTEN BOLTS SECURELY.

3b) FASTENING STAIR TREAD ASSEMBLY TO RISER

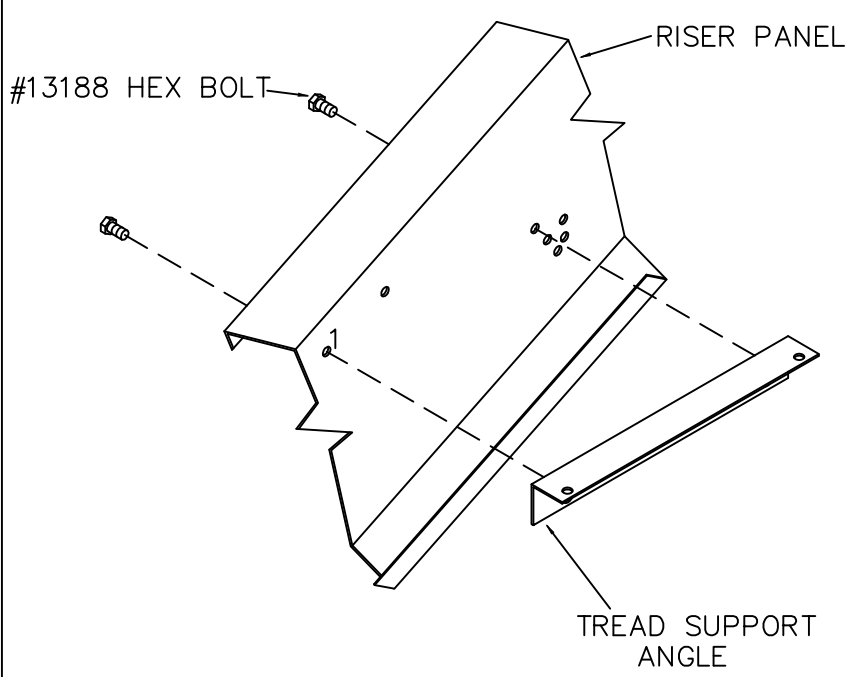

NOTE
STAIR TREAD NOT SHOWN FOR CLARITY.
BOLT TREAD SUPPORT ANGLE TO HOLE
1 IN THE RISER PANEL. LEVEL TREAD
SUPPORT ANGLE AND BOLT THE OTHER
END OF ANGLE IN THIS POSITION.
DO NOT TIGHTEN TREADS UNTIL ALL
STAIR TREADS ARE IN PLACE.

#13188 HEX HEAD BOLT 3/8"-16 x 3/4"
#13191 HEX NUT 3/8"-16
#13182 SPRING LOCKWASHER 3/8"
(2 PER SUPPORT ANGLE)

FULL SCALE

4

SWAY BRACE ASSEMBLY

FOR F08 THROUGH F10 STAIRWAYS

NOTE:
NO BRACE NEEDED FOR F04
THROUGH F07 STAIRWAYS.

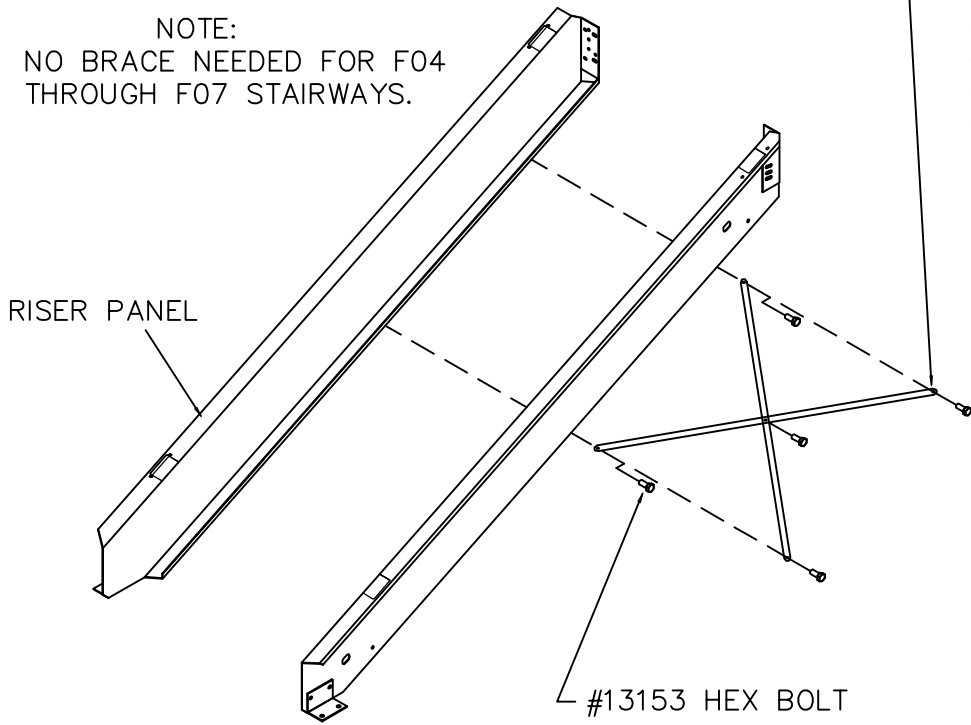

BRACE

- #6492 - 24" WIDE STAIRWAY
- #6493 - 30" WIDE STAIRWAY
- #6494 - 36" WIDE STAIRWAY
- #6459 - 48" WIDE STAIRWAY

NOTE

BOLT ONE PAIR OF BRACES IN THE
SECOND AND FOURTH HOLE FROM
THE TOP.
TIGHTEN BOLTS SECURELY.

- #13153 HEX BOLT 5/16"-18 x 3/4"
- #13051 LOCK NUT 5/16-18
- (5 PER PAIR OF BRACES)



FOR F11 THROUGH F17 STAIRWAYS

RISER PANELS
(NOTE: REFER TO 061ASY
INSTRUCTIONS FOR (2)
PIECE CONSTRUCTION)

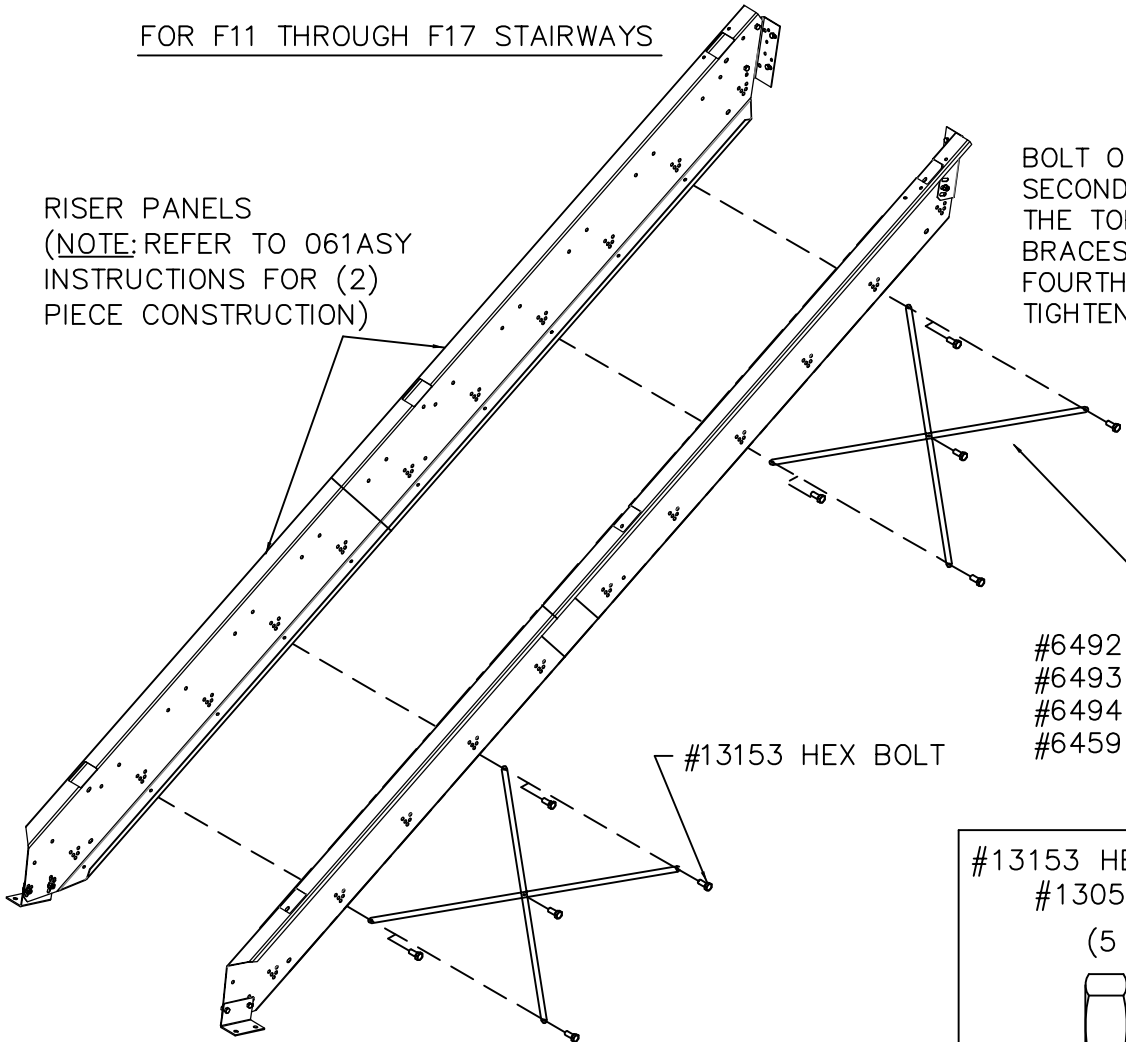

NOTE

BOLT ONE PAIR OF BRACES IN THE
SECOND AND FOURTH HOLE FROM
THE TOP AND A SECOND PAIR OF
BRACES IN THE SECOND AND
FOURTH HOLE FROM THE BOTTOM.
TIGHTEN BOLTS SECURELY.

BRACE

- #6492 - 24" WIDE STAIRWAY
- #6493 - 30" WIDE STAIRWAY
- #6494 - 36" WIDE STAIRWAY
- #6459 - 48" WIDE STAIRWAY

- #13153 HEX BOLT 5/16"-18 x 3/4"
- #13051 LOCK NUT 5/16-18
- (5 PER PAIR OF BRACES)



STAIR RAILING ASSEMBLY

1 RAILING POST ASSEMBLY

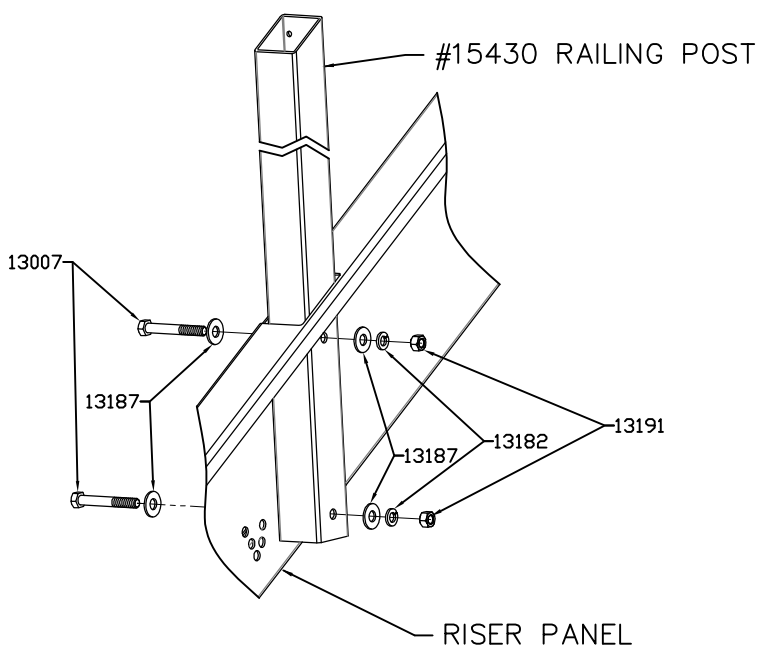

NOTE

INSERT POST THRU SLOT IN RISER PANEL SO THAT THE HOLES IN THE TOP OF THE POST ARE FACING TOWARD TOP OF THE STAIRWAY. BOLT POSTS TO RISER PANEL AS SHOWN. DO NOT TIGHTEN THESE BOLTS UNTIL COMPLETE RAIL IS ASSEMBLED.

#13007 HEX HEAD BOLT 3/8"-16 x 2 3/4"
 #13191 HEX NUT 3/8"-16
 #13182 SPRING LOCKWASHER 3/8"
 #13187 FLAT WASHER 3/8" (2 PER BOLT)

FULL SCALE

2 TOP HAND RAIL ASSEMBLY

2a) FOR F04 THROUGH F10 STAIRWAYS
POST BRACKET ASSEMBLY TO TOP HAND RAILS

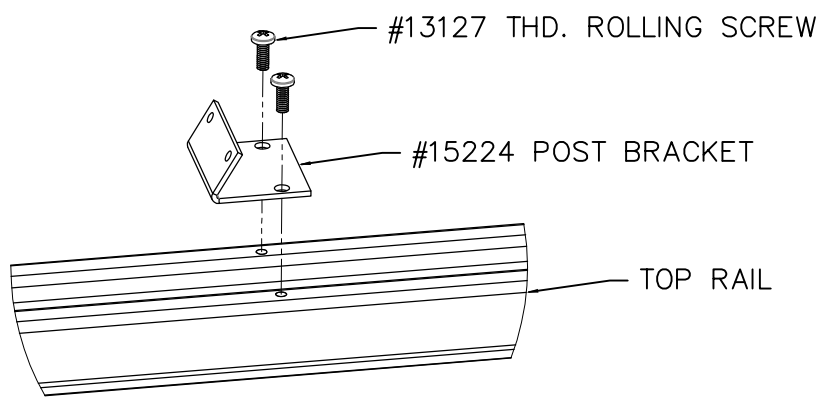

NOTE

INSTALL BRACKET SO IT POINTS TOWARD TOP END OF RAIL. TIGHTEN BOLTS SECURELY.

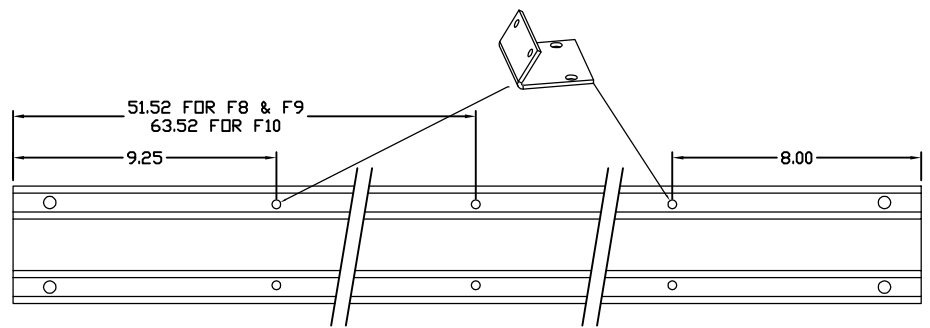

TOP HAND RAIL TOP END

TOP HAND RAIL BOTTOM END

#13127 #8-32 X 7/16 PH. PAN HEAD THRD ROLLING SCREW (2 PER ASSEMBLY)

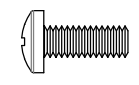

FULL SCALE

TOP HAND RAILING ASSEMBLY TO VERTICAL POSTS

NOTE

BE SURE ALL POST BRACKETS ARE FASTENED SECURELY TO TOP RAIL. LOWER TOP RAIL OVER TOPS OF POSTS WITH BRACKETS INSIDE. FASTEN IN PLACE SECURELY.

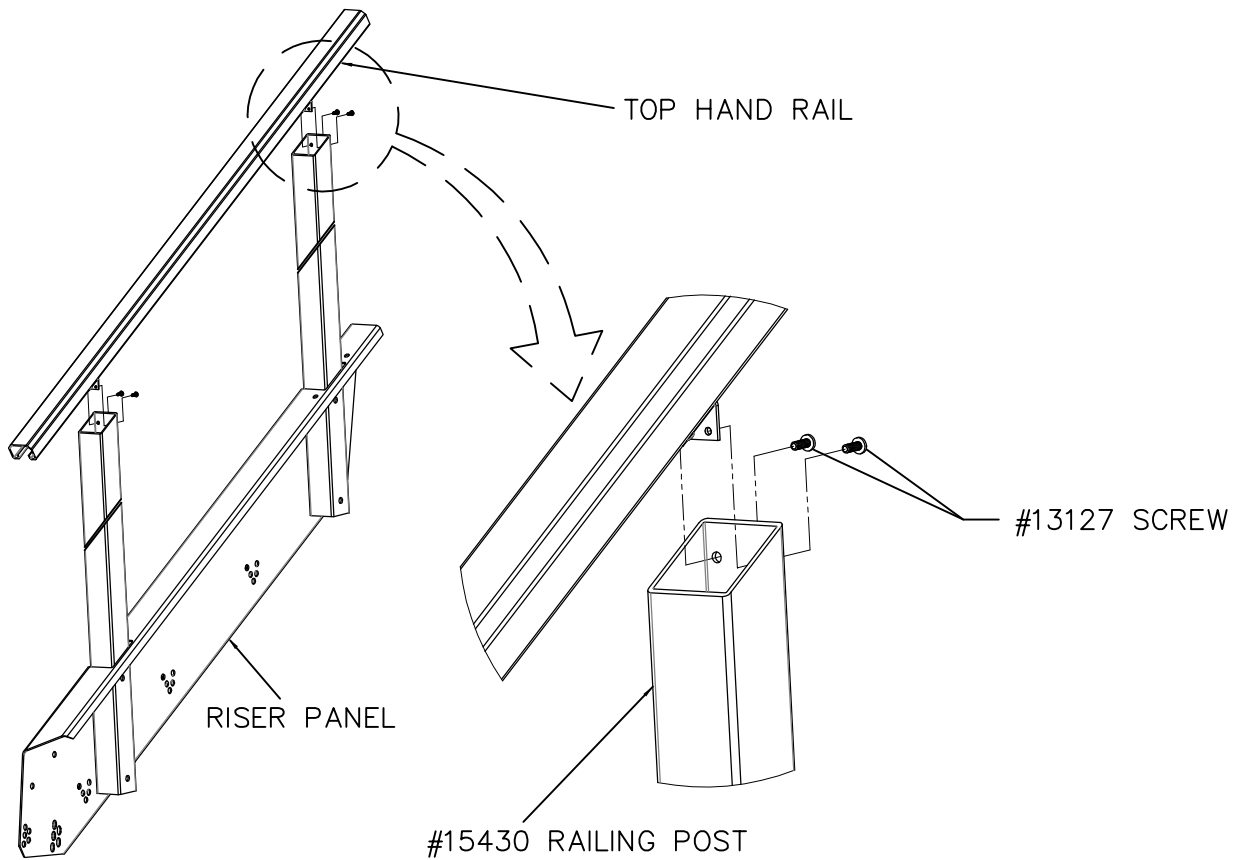

#13127 #8-32 X 7/16 PH. PAN HEAD THRD ROLLING SCREW (2 PER ASSEMBLY)

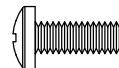

FULL SCALE

2b) FOR F11 THROUGH F12 STAIRWAYS
TOP HAND RAIL ASSEMBLY TO VERTICAL POST

NOTE

ASSEMBLE POST BRACKET TO TOP HAND RAIL
IN THE SAME WAY AS SHOWN AT STEP 2a.
MAKE SURE ALL BRACKETS ARE TIGHTENED
SECURELY TO TOP HAND RAIL AND FASTEN
THE RAIL TO POSTS AS SHOWN.

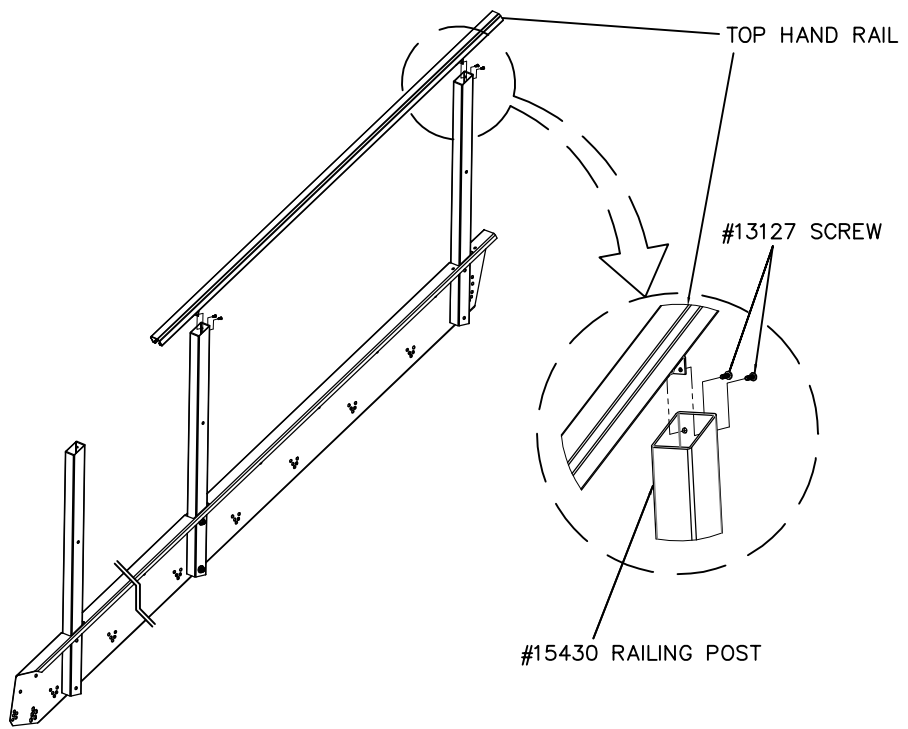
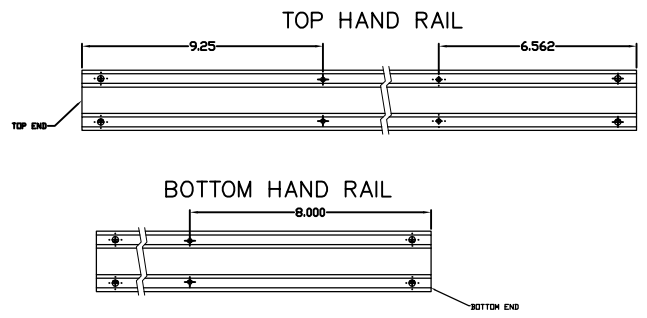

SLEEVE ASSEMBLY INTO TOP HAND RAIL

NOTE

INSERT SLEEVE INTO BOTTOM END OF TOP HAND RAIL AS SHOWN. ALIGN THE UPPER SET OF HOLES IN THE SLEEVE WITH THE HOLES IN THE HAND RAIL. FASTEN IN PLACE AND TIGHTEN SECURELY.

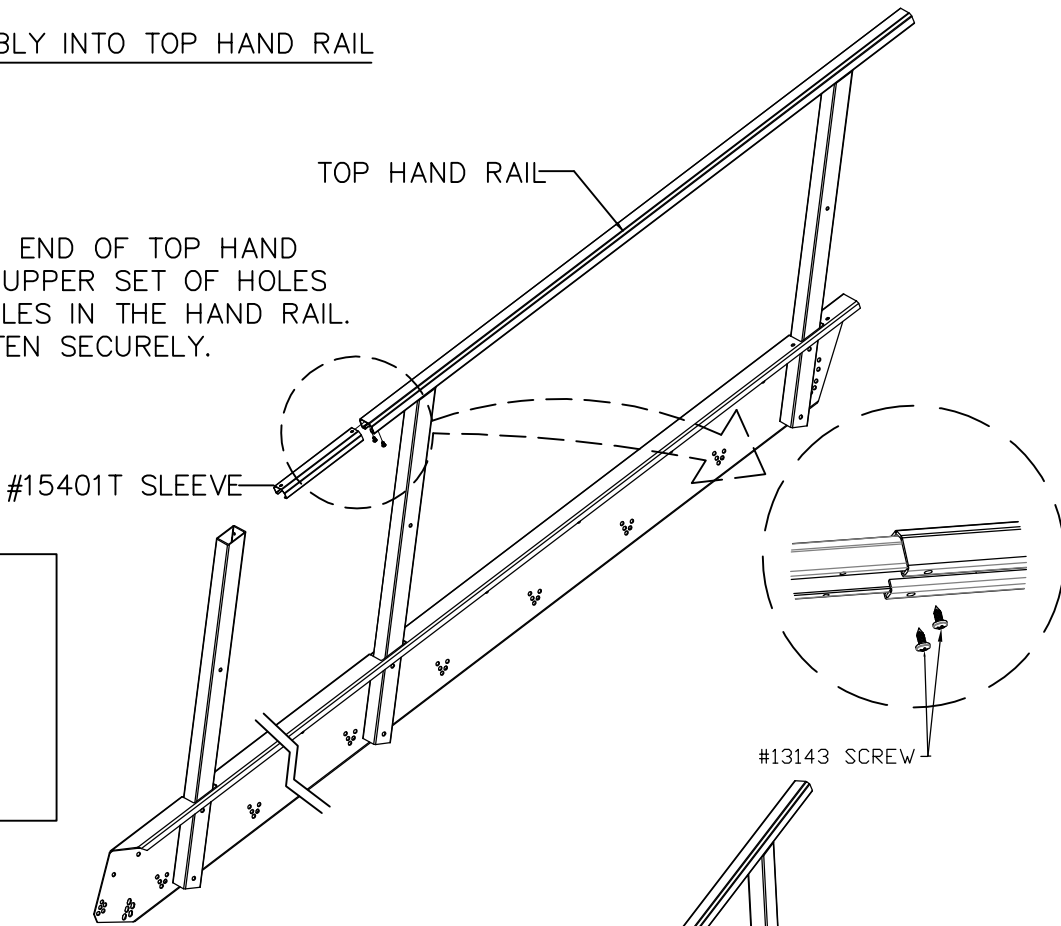

#13143 PH. PAN HD SHEET METAL SCREW #10-24 X 1/2" (4 PER SLEEVE)

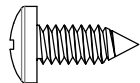

FULL SCALE

BOTTOM HAND RAIL ASSEMBLY TO VERTICAL POST

NOTE

ASSEMBLE POST BRACKET TO BOTTOM HAND RAIL. TIGHTEN THE BRACKET SECURELY. TELESCOPE THE END OF THE BOTTOM RAIL OVER THE SLEEVE EXTENDING FROM TOP HAND RAIL AND AT THE SAME TIME PLACE BOTTOM HAND RAIL POST BRACKET INSIDE POST. TIGHTEN ALL SCREWS SECURELY.

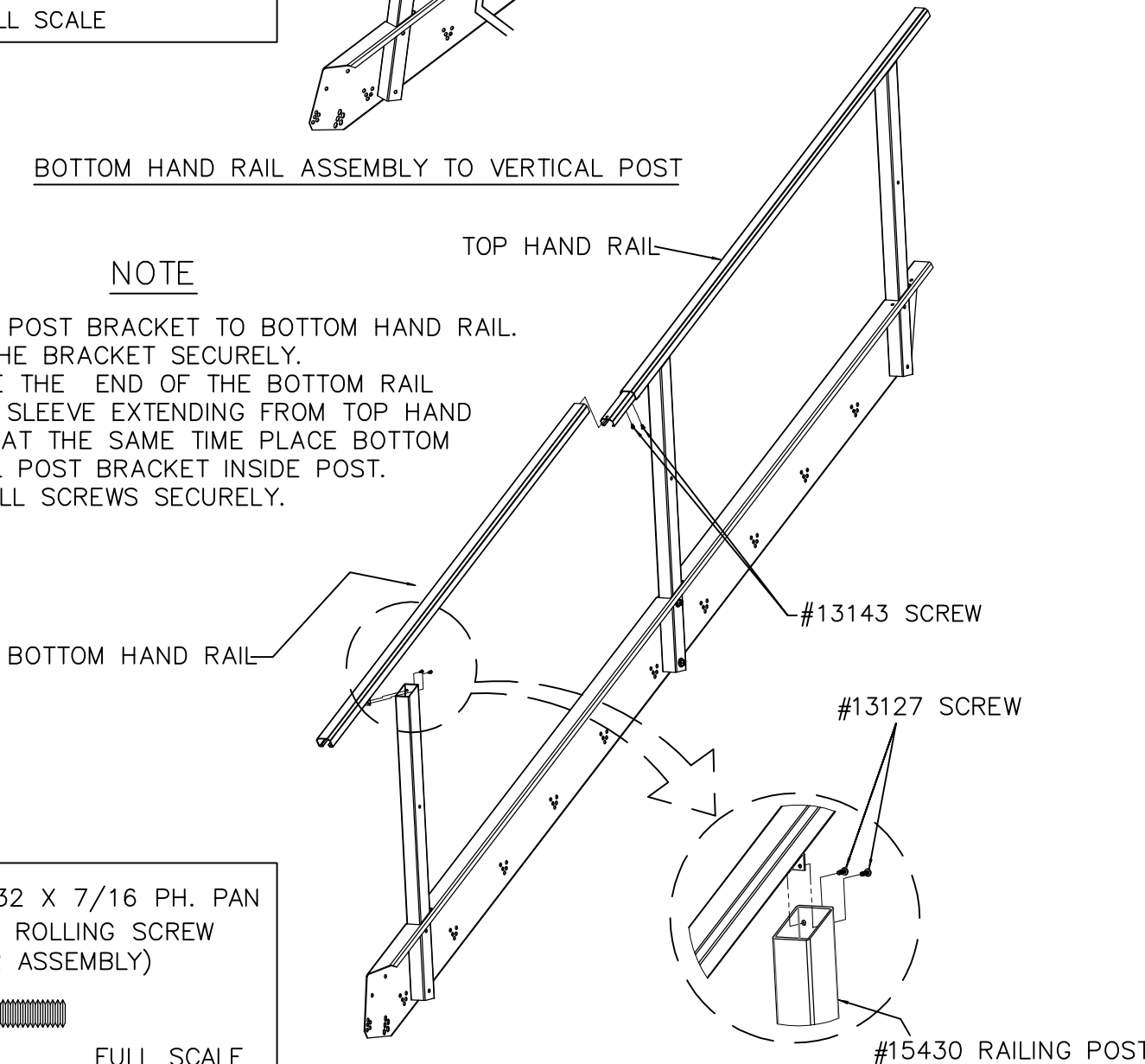

#13127 #8-32 X 7/16 PH. PAN HEAD THRD ROLLING SCREW (2 PER ASSEMBLY)

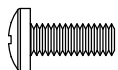

FULL SCALE

2c) FOR F14 THROUGH F17 STAIRWAYS

HAND RAIL ASSEMBLY TO VERTICAL POST

NOTE

ASSEMBLE POST BRACKETS TO TOP HAND RAIL AND ASSEMBLE TOP HAND RAIL TO POSTS AS SHOWN AT STEP 2b. ASSEMBLE SLEEVE INTO BOTTOM END OF TOP HAND RAIL AS SHOWN AT STEP 2b. ASSEMBLE POST BRACKET TO MIDDLE RAIL AS SHOWN AT STEP 2b. TELESCOPE THE END OF THE MIDDLE RAIL OVER THE SLEEVE EXTENDING FROM TOP HAND RAIL AND AT THE SAME TIME PLACE MIDDLE RAIL POST BRACKET INSIDE THE POST. TIGHTEN ALL SCREWS SECURELY.

#13143 PH. PAN HD
SHEET METAL SCREW
#10-24 X 1/2"
(4 PER SLEEVE)

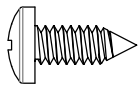

FULL SCALE

#13127 #8-32 X 7/16 PH. PAN
HEAD THRD ROLLING SCREW
(2 PER ASSEMBLY)

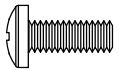

FULL SCALE

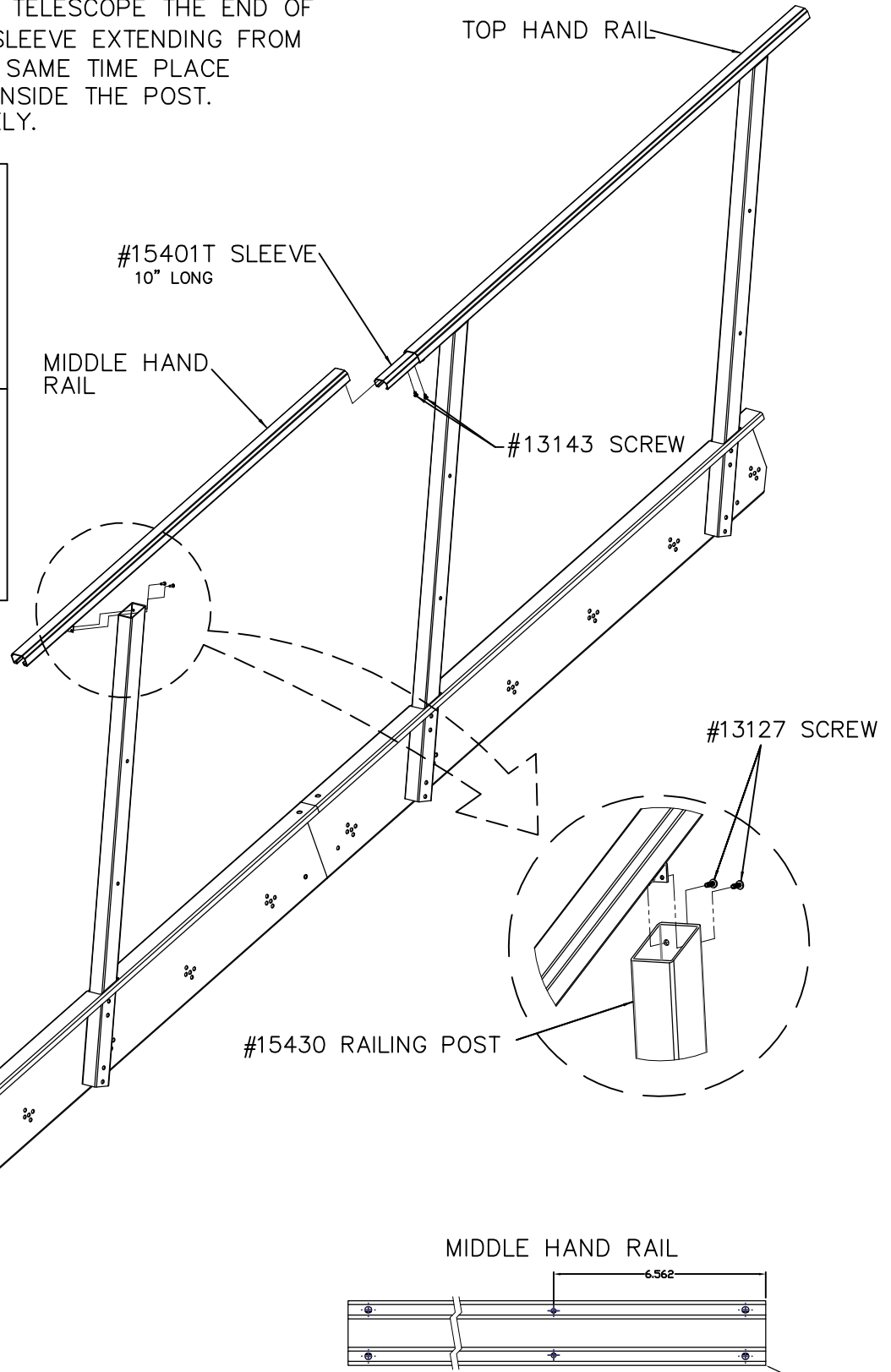

TOP HAND RAIL

#15401T SLEEVE
10" LONG

MIDDLE HAND
RAIL

#13143 SCREW

#13127 SCREW

#15430 RAILING POST

MIDDLE HAND RAIL

6.562

SEE STEP 2b FOR TOP AND
BOTTOM RAIL DIMENSIONS

BOTTOM END

ASSEMBLE BOTTOM HAND RAIL TO VERTICAL POST

NOTE

ASSEMBLE POST BRACKET TO BOTTOM HAND RAIL.
TIGHTEN BRACKET SECURELY.
ASSEMBLE SLEEVE INTO BOTTOM END OF MIDDLE
RAIL AS SHOWN AT STEP 2b. TELESCOPE THE END OF
BOTTOM HAND RAIL OVER THE SLEEVE EXTENDING
FROM MIDDLE RAIL AND AT THE SAME TIME PLACE
BOTTOM HAND RAIL POST BRACKET INSIDE POST.
TIGHTEN ALL SCREWS SECURELY.

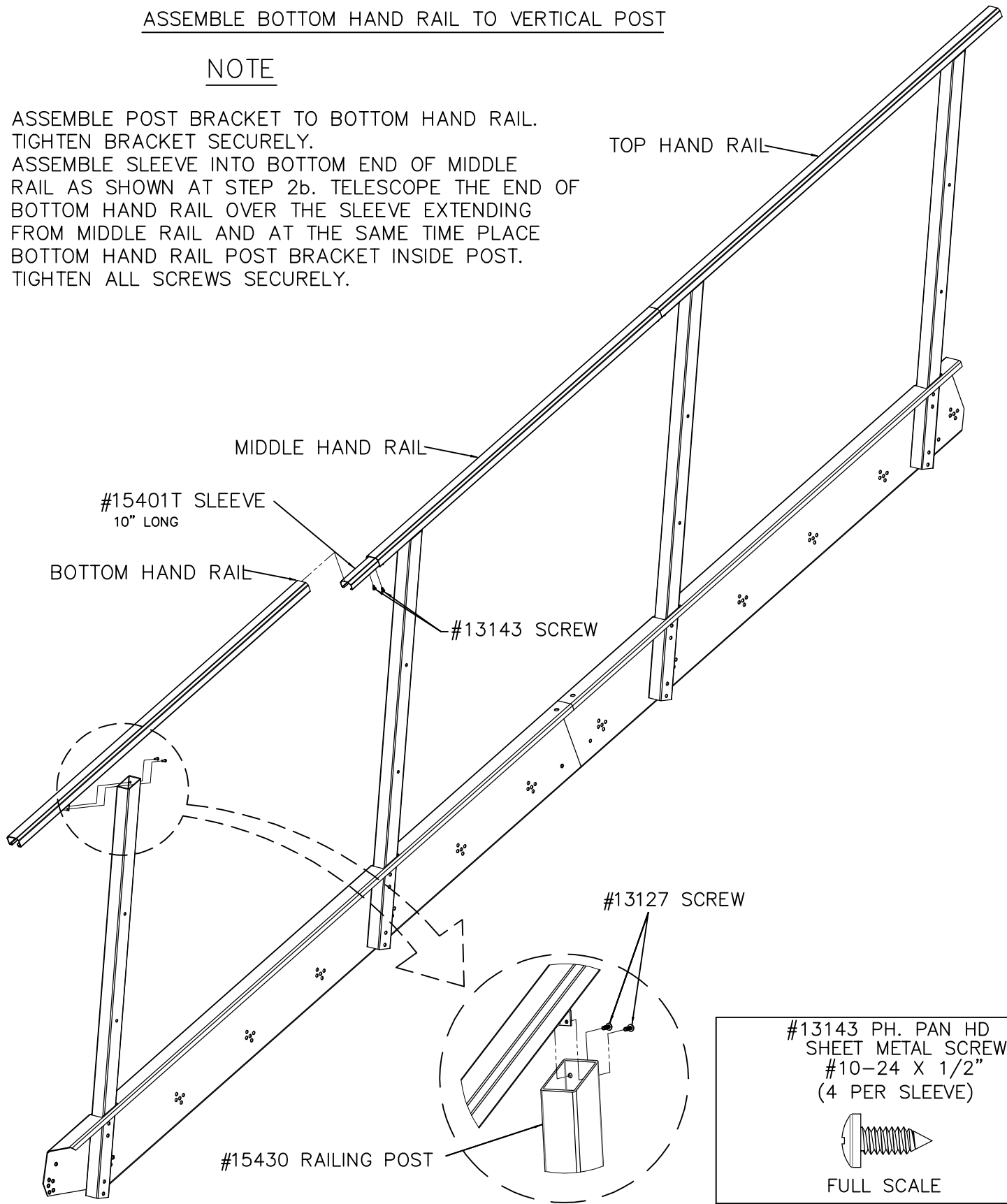

#13143 PH. PAN HD
SHEET METAL SCREW
#10-24 X 1/2"
(4 PER SLEEVE)

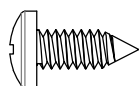

FULL SCALE

#13127 #8-32 X 7/16 PH. PAN
HEAD THRD ROLLING SCREW
(2 PER ASSEMBLY)

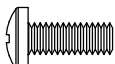

FULL SCALE

3 BOTTOM AND END RAILS ASSEMBLY

3a) FOR F04 THROUGH F7 STAIRWAYS

NOTE

RISER NOT SHOWN FOR CLARITY.
 INSERT ALL BOLTS WITH THE HEAD
 TOWARD THE INSIDE OF THE STAIRWAY.
 DO NOT TIGHTEN FASTENERS UNTIL
 ALL BOTTOM AND END RAILS HAVE
 BEEN INSTALLED.

NOTE

SEE CHARTS ON PAGE 18-20
 FOR TOP AND BOTTOM RAILING LENGTHS
 AND SEQUENCE OF ASSEMBLY

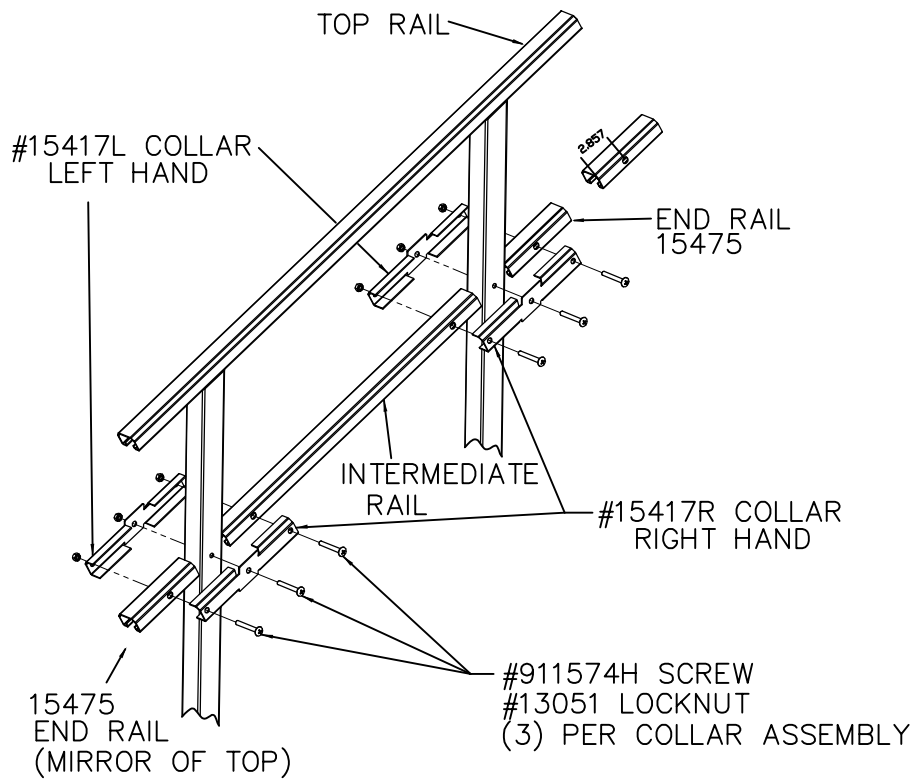

#911574H TRUSS HD MACH SCREW
 5/16" - 18 X 2 1/2"
 #13051 LOCKNUT
 5/16" - 18
 (3 PER PAIR OF COLLARS)

FULL SCALE

3 BOTTOM AND END RAILS ASSEMBLY

3b) FOR F8 THROUGH F12 STAIRWAYS

F14 AND F17 STAIRWAYS WILL
HAVE (4) POST LOCATIONS

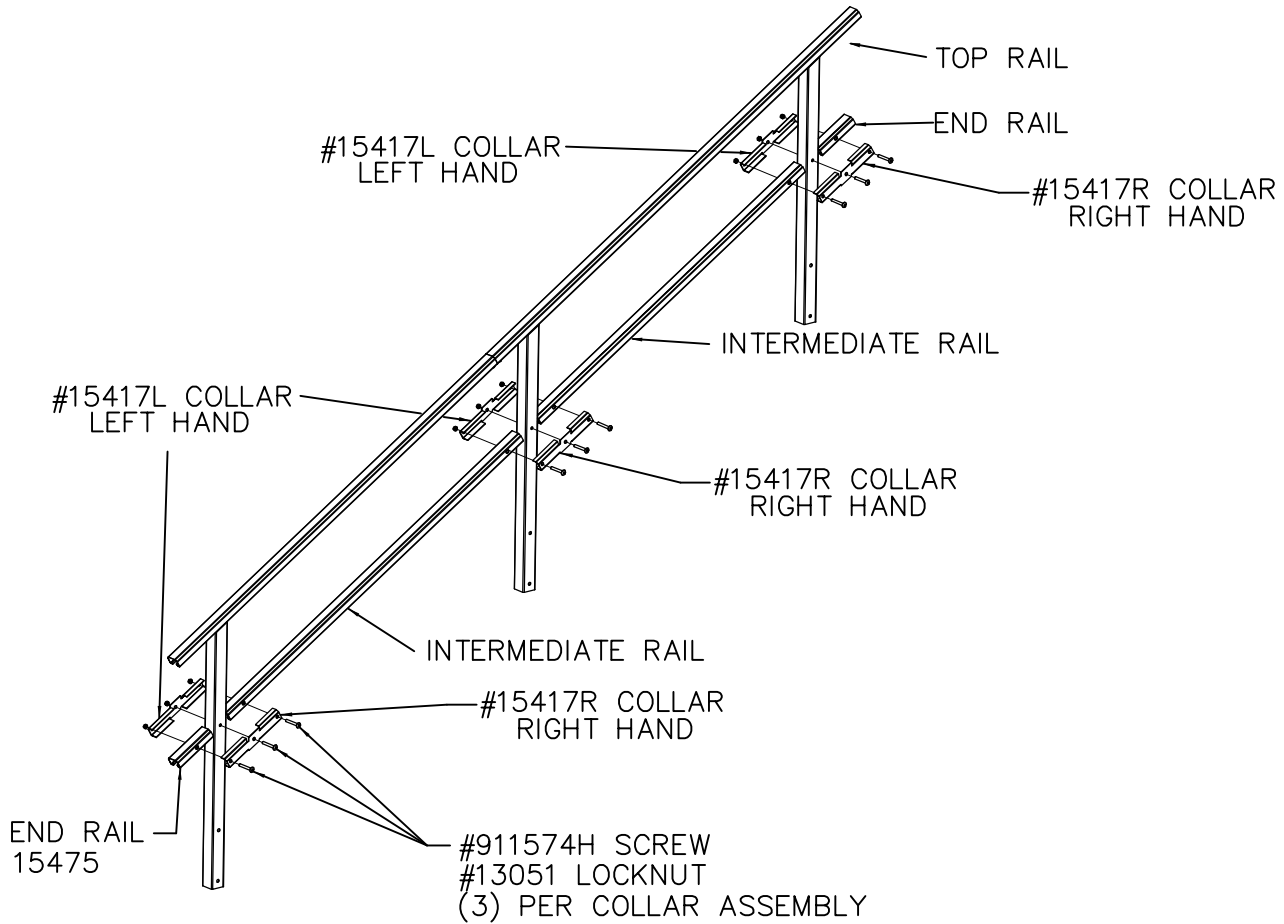

NOTE

RISER NOT SHOWN FOR CLARITY.
INSERT ALL BOLTS WITH THE HEAD
TOWARD THE INSIDE OF THE STAIRWAY.
DO NOT TIGHTEN FASTENERS UNTIL
ALL BOTTOM AND END RAILS HAVE
BEEN INSTALLED.

#911574H TRUSS HD MACH SCREW
5/16" - 18 X 2 1/2"
#13051 LOCKNUT
5/16" - 18
(3 PER PAIR OF COLLARS)



FULL SCALE

RAILING PLUG, POST PLUG AND SLOT COVER ASSEMBLY

4

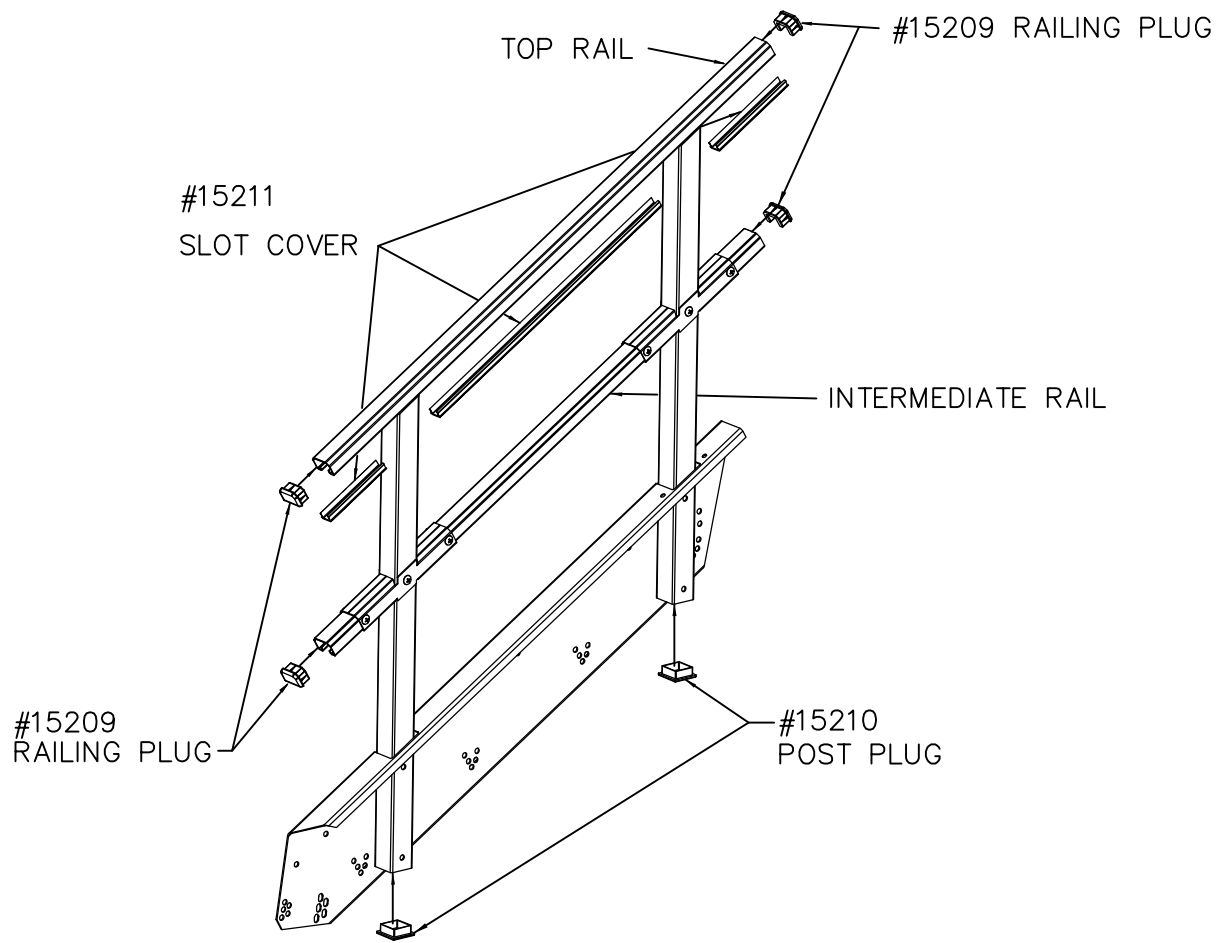

NOTE

INSTALL RAILING PLUGS IN BOTH ENDS OF TOP AND BOTTOM RAILS. INSTALL POST PLUGS IN VISIBLE BOTTOM ENDS OF THE RAILING POSTS. FIELD CUT SLOT COVER AND INSTALL IN TOP RAIL ONLY.

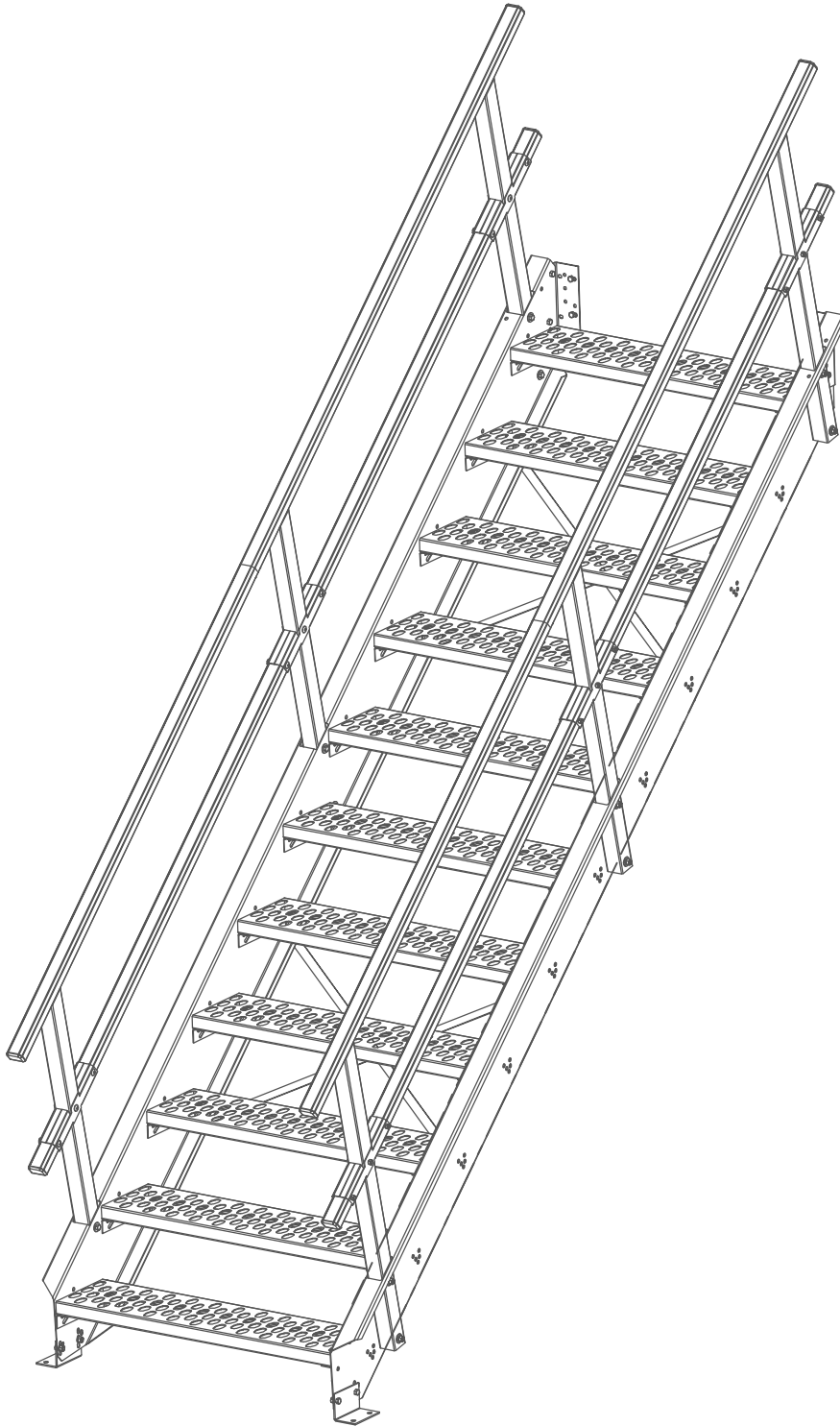

F04-F07 RAILING CHART

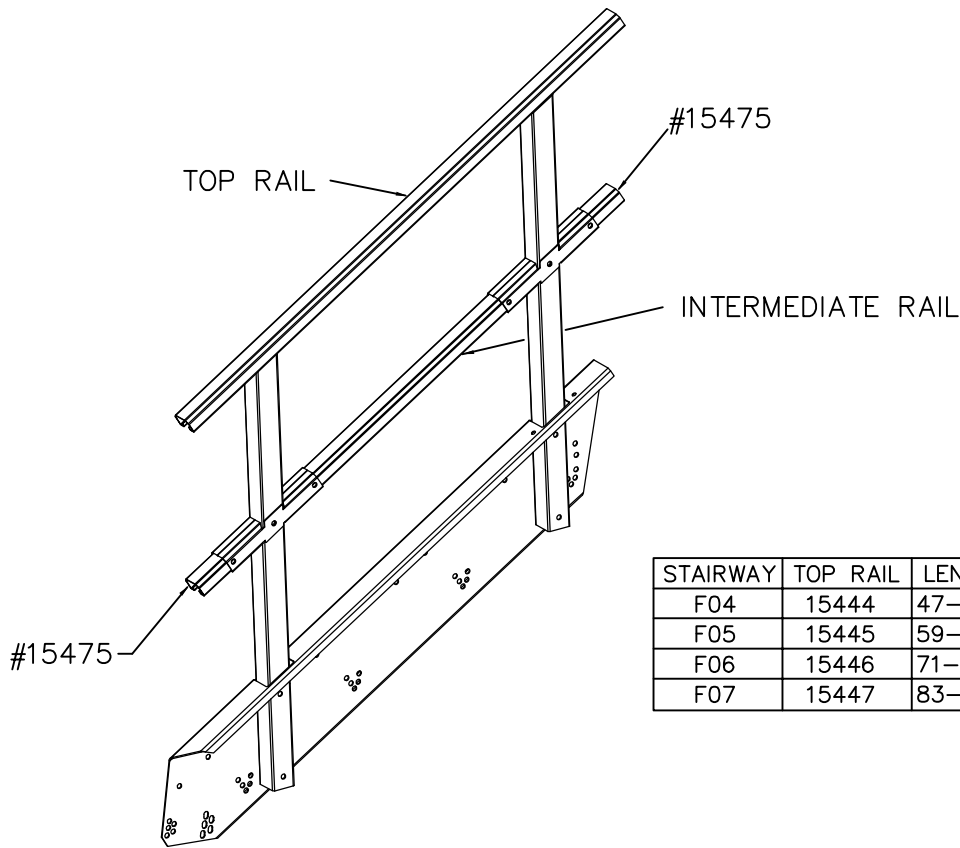

STAIRWAY	TOP RAIL	LENGTH	INTER. RAIL	LENGTH
F04	15444	47-3/4"	15434	27-3/32"
F05	15445	59-3/4"	15435	39-3/32"
F06	15446	71-3/4"	15441UR	51-3/32"
F07	15447	83-3/4"	15437UR	63-3/32"

F08-F10 RAILING CHART

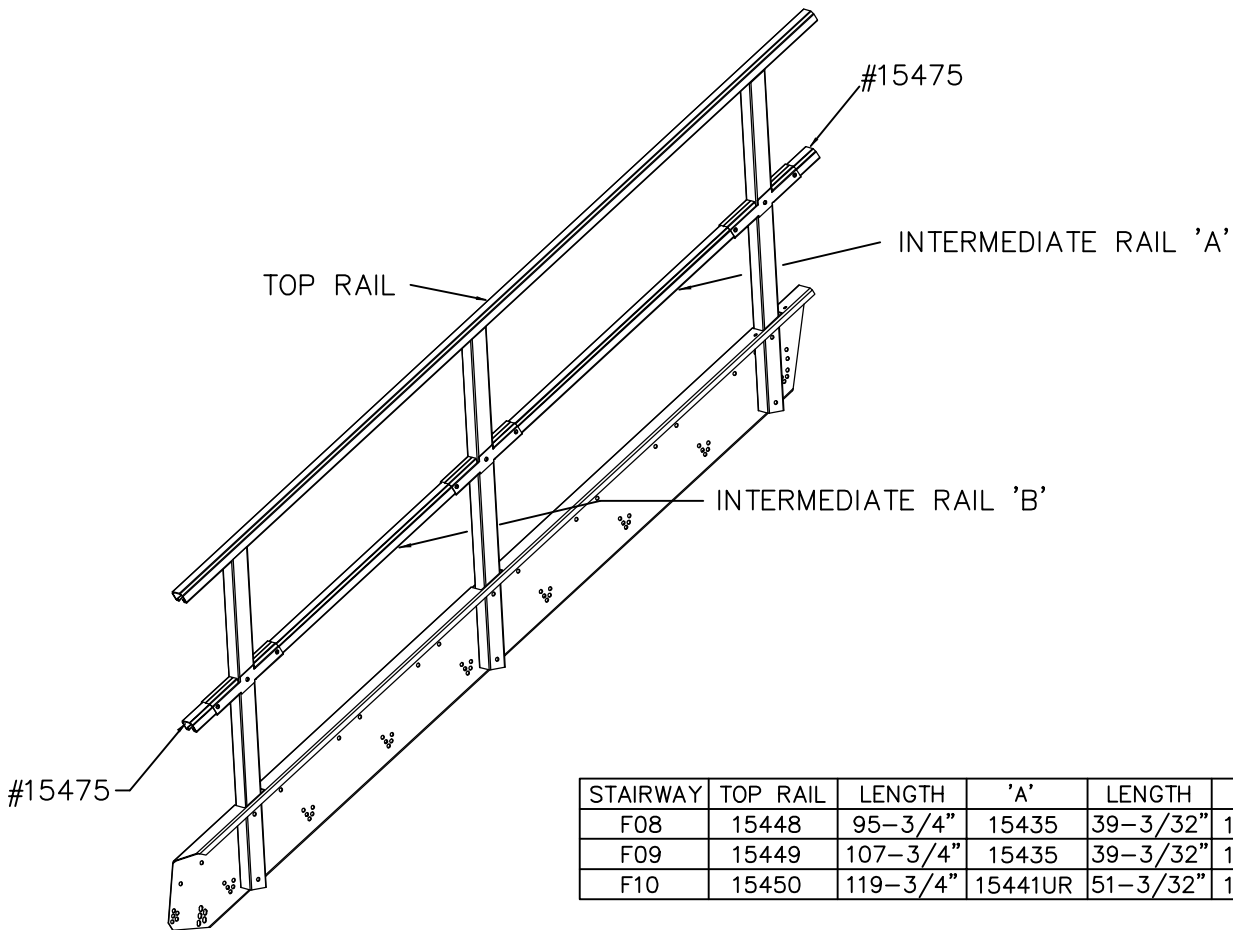

STAIRWAY	TOP RAIL	LENGTH	'A'	LENGTH	'B'	LENGTH
F08	15448	95-3/4"	15435	39-3/32"	15481LR	32-19/32"
F09	15449	107-3/4"	15435	39-3/32"	15480LR	44-19/32"
F10	15450	119-3/4"	15441UR	51-3/32"	15480LR	44-19/32"

F11-F12 RAILING CHART

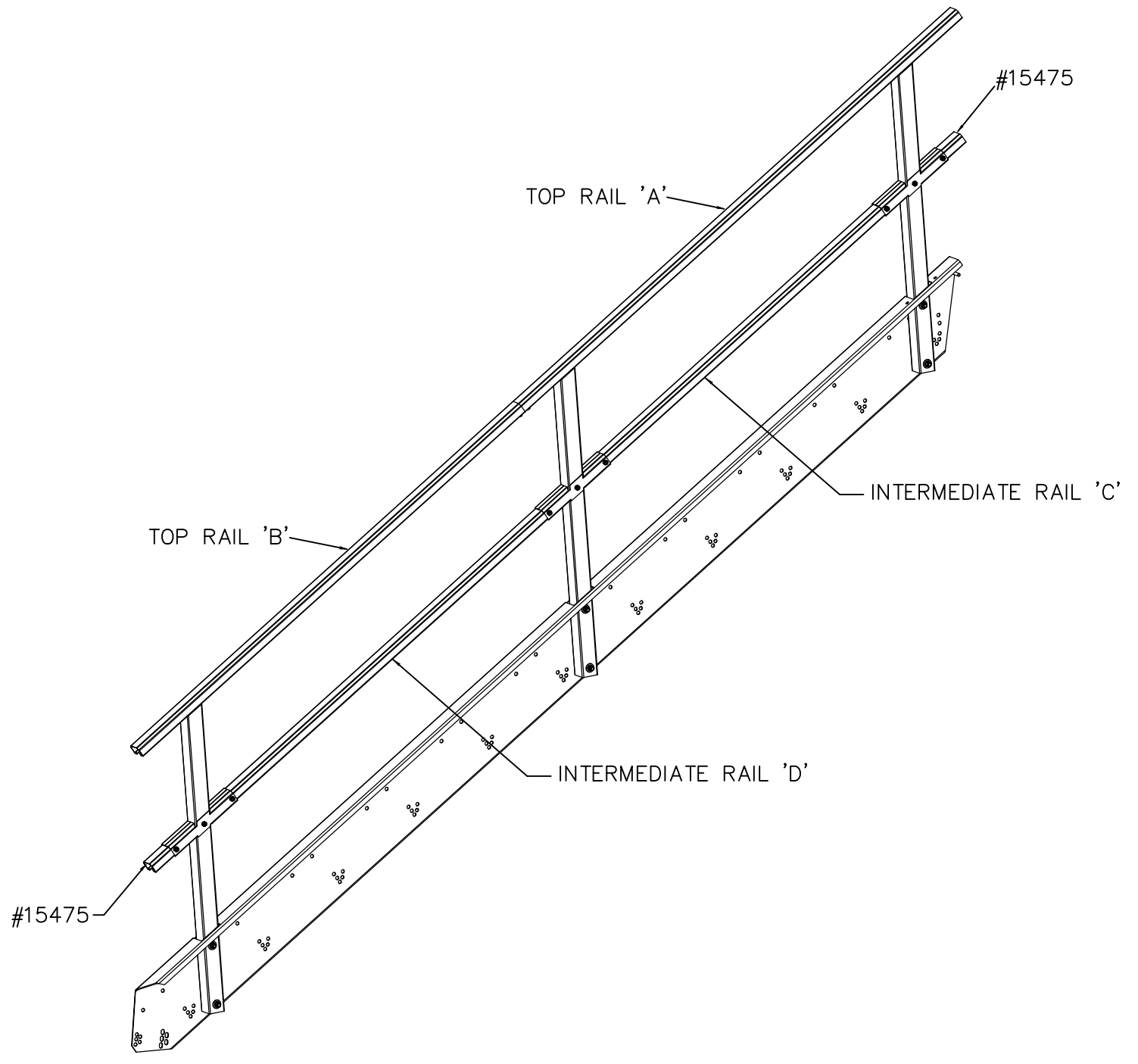

STAIRWAY	'A'	LENGTH	'B'	LENGTH	'C'	LENGTH	'D'	LENGTH
F11	15451UR	70-5/16"	15451LR	61-7/16"	15441UR	51-3/32"	15441LR	56-19/32"
F12	15453UR	82-5/16"	15451LR	61-7/16"	15437UR	63-3/32"	15441LR	56-19/32"

F14-F17 RAILING CHART

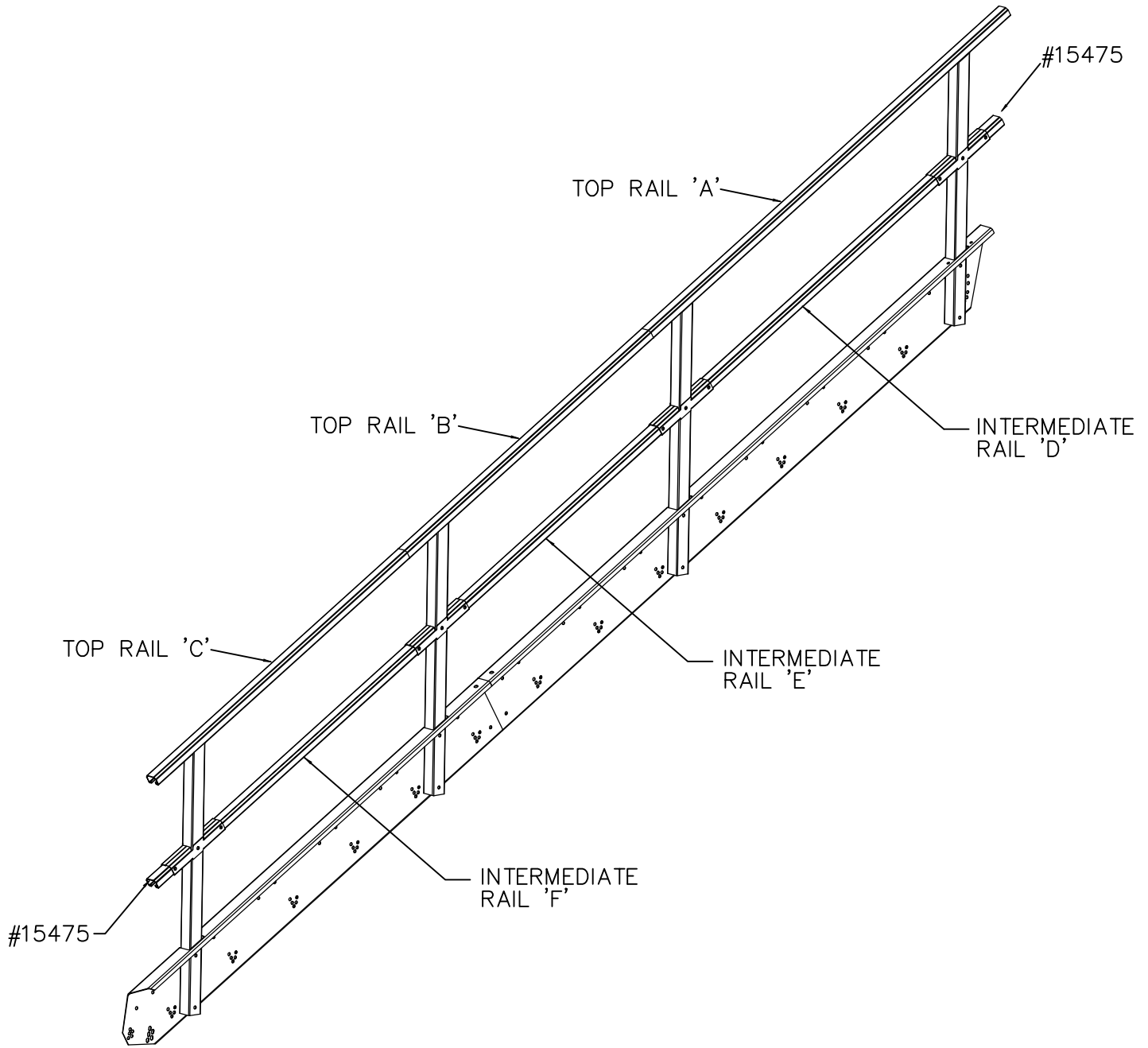

STAIRWAY	'A'	LENGTH	'B'	LENGTH	'C'	LENGTH	'D'	LENGTH	'E'	LENGTH	'F'	LENGTH
F14	15451UR	70-5/16"	15483MR	47-31/32"	15482LR	49-7/16"	15441UR	51-3/32"	15480LR	44-19/32"	15480LR	44-19/32"
F17	15451UR	70-5/16"	15484MR	59-31/32"	15452LR	73-7/16"	15441UR	51-3/32"	15441LR	56-19/32"	15438LR	68-19/32"