

12311ASY

THIS DRAWING IS THE PROPERTY OF

**EQUIPTO**

60ASY  
REVISED 9-5-07

Toll-free Tel: 800-323-0801 Toll-free Fax: 888-859-2121 www.equipto.com

# SHELVING WIDE DRAWERS ASSEMBLY INSTRUCTIONS

## Step

### 1 POST AND BRACKET ASSEMBLY

#### a) V-GRIP POST BRACKET

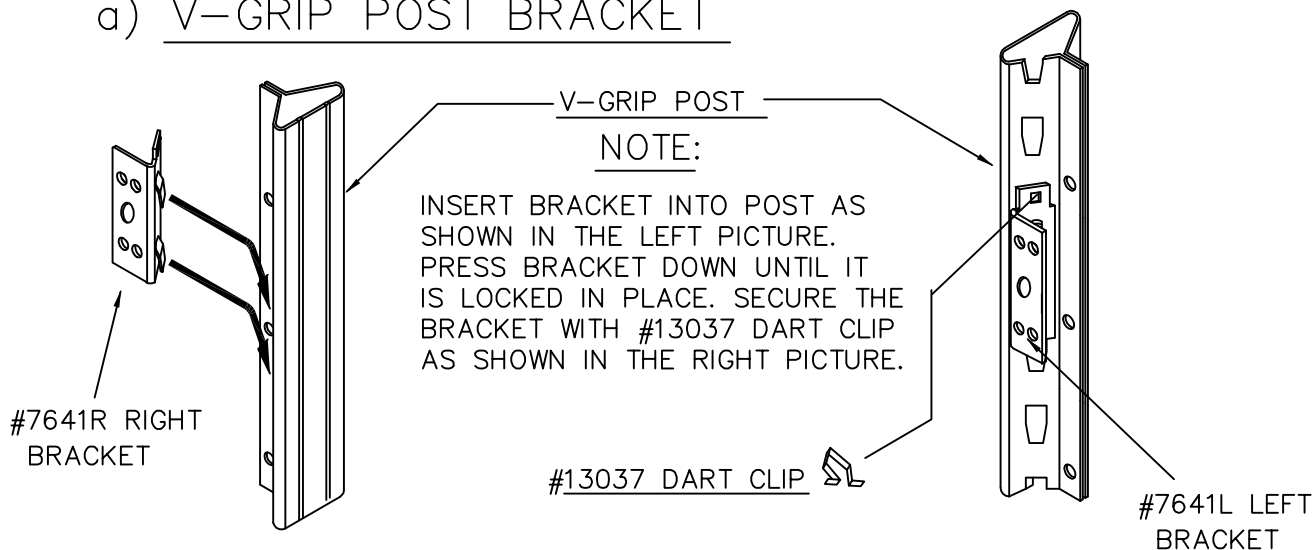

#### b) IRON GRIP POST BRACKET

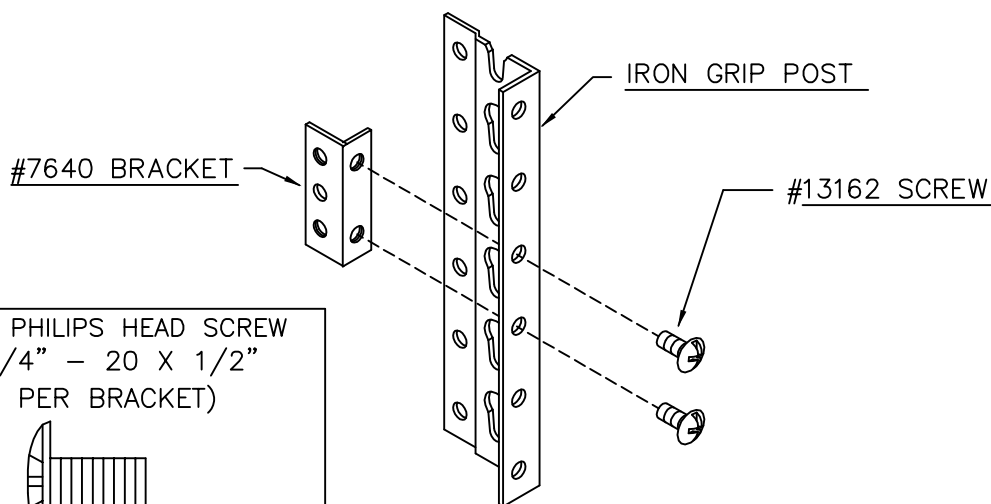

**#13162 PHILIPS HEAD SCREW**  
1/4" - 20 X 1/2"  
(2 PER BRACKET)

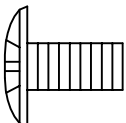

FULL SCALE

# Step

2

## CHANNEL ASSEMBLY

### a) V-GRIP POST BRACKET

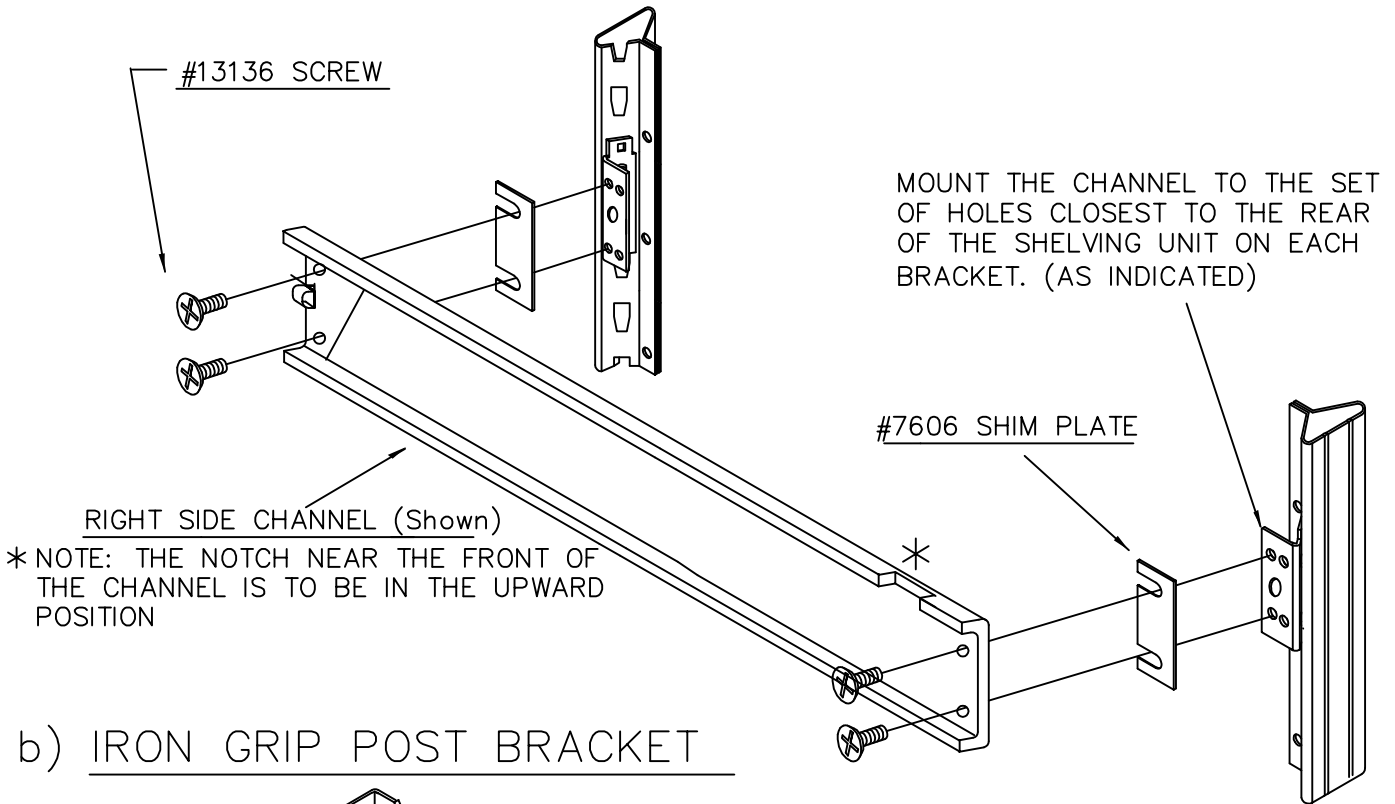

### b) IRON GRIP POST BRACKET

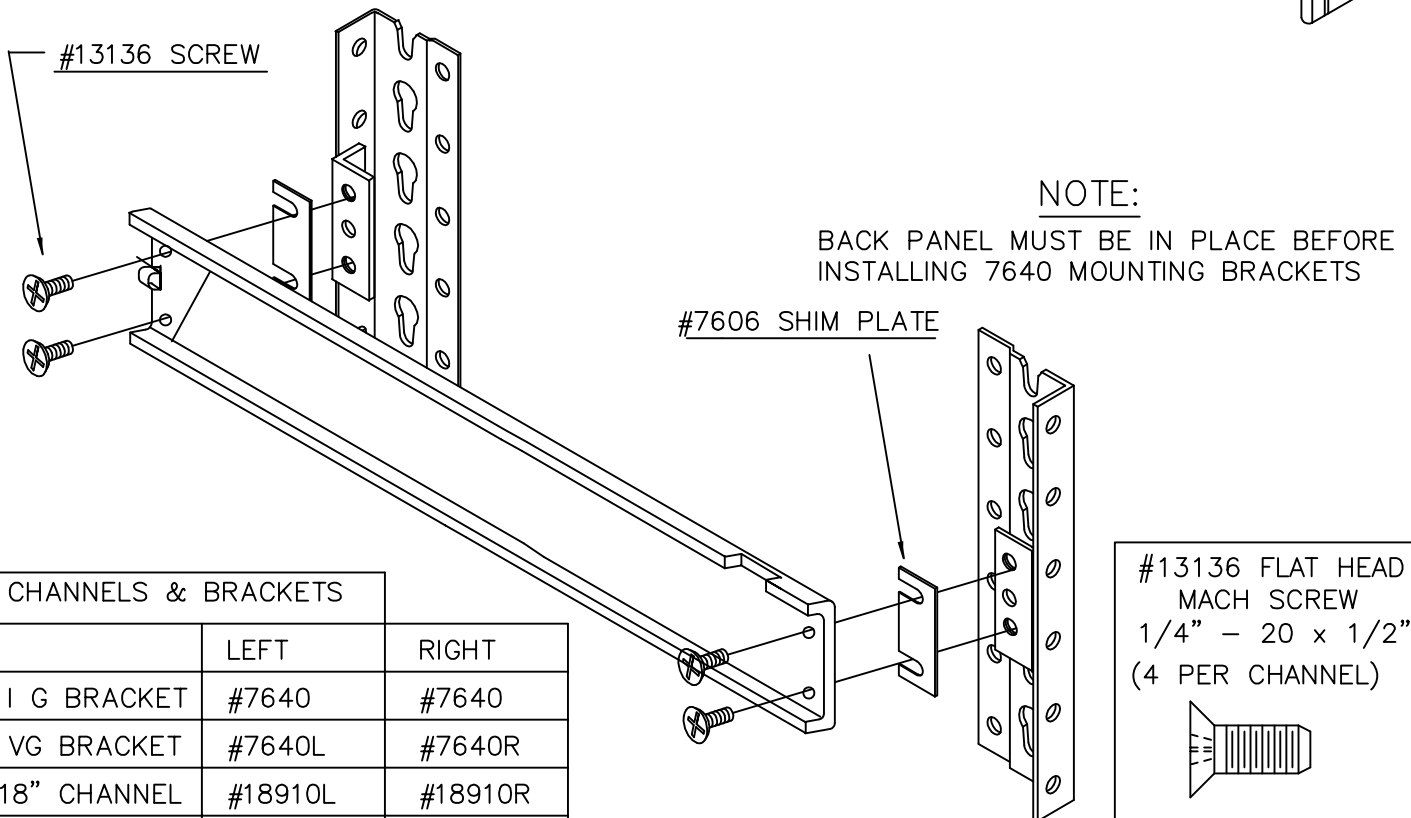

CHANNELS & BRACKETS		
	LEFT	RIGHT
I G BRACKET	#7640	#7640
VG BRACKET	#7640L	#7640R
18" CHANNEL	#18910L	#18910R
24" CHANNEL	#18911L	#18911R

#13136 FLAT HEAD MACH SCREW  
1/4" - 20 x 1/2"  
(4 PER CHANNEL)

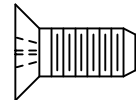

FULL SCALE

3

# CARRIAGE & DRAWER INSTALLATION

INSERT CARRIAGE INTO CHANNELS. INSTALL DRAWER INTO CARRIAGE. IT IS NECESSARY TO PULL CARRIAGE OUT TO STOPS TO INSTALL 3" HIGH DRAWERS

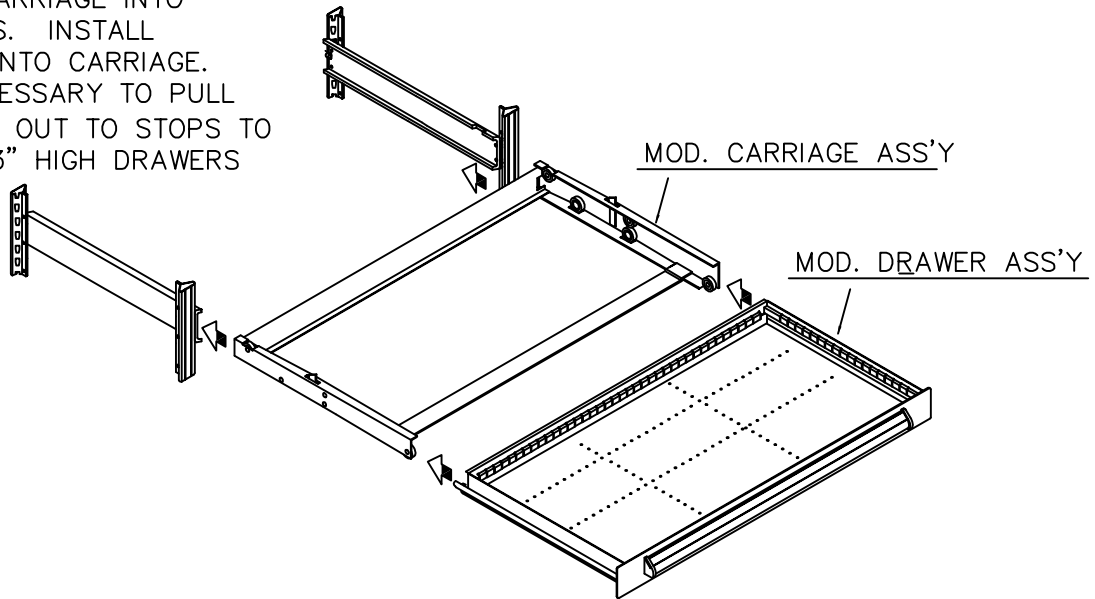

DRAWERS	DRAWER ONLY		DRAWER & V GRIP MOUNTING ACCESSORIES		DRAWER & IRON GRIP MOUNTING ACCESSORIES	
	18" DEEP	24" DEEP	18" DEEP	24" DEEP	18" DEEP	24" DEEP
36" WIDE						
3" HIGH DRAWER	8603A	8610A	8603H	8610H	8603IH	8610IH
4 1/2" H DRAWER	8604A	8611A	8604H	8611H	8604IH	8611IH
6" HIGH DRAWER	8605A	8612A	8605H	8612H	8605IH	8612IH
7 1/2" H DRAWER	8606A	8613A	8606H	8613H	8606IH	8613IH
9" HIGH DRAWER	8601A	8615A	8601H	8615H	8601IH	8615IH
12" HIGH DRAWER	8607A	8614A	8607H	8614H	8607IH	8614IH
DRAWERS	DRAWER ONLY		DRAWER & V GRIP MOUNTING ACCESSORIES		CARRIAGES	
	18" DEEP	24" DEEP	18" DEEP	24" DEEP	36" WIDE	
48" WIDE						
3" HIGH DRAWER	8661A	8670A	8661H	8670H	18" DEEP	18918
4 1/2" H DRAWER	8662A	8671A	8662H	8671H	24" DEEP	18919
6" HIGH DRAWER	8663A	8672A	8663H	8672H	48" WIDE	
7 1/2" H DRAWER	8664A	8673A	8664H	8673H		
9" HIGH DRAWER	8665A	8674A	8665H	8674H	18" DEEP	18937
10 1/2" H DRAWER	8666A	8675A	8666H	8675H	24" DEEP	18938
12" FILE DRAWER	8667FA	8676FA	-	-		
12" HIGH DRAWER	8667A	8676A	8667H	8676H		
13 1/2 H DRAWER	8668A	8677A	8668H	8677H		

# PARTITION ASSEMBLY

MODULAR CABINET DEPTH	PARTITION HEIGHT					
	FRONT TO BACK PARTITION			SIDE TO SIDE PARTITION		
	2"	3"	4 1/2"	2"	3"	4 1/2"
18" DEEP	8780N	8781N	8782N	8770	8771	8772
24" DEEP	8790N	8791N	8792N	8770	8771	8772

NOTE:

LOCATE PARTITIONS TO FIT  
DIVIDERS WHEN USED.

SIDE TO SIDE  
PARTITION  
(Available for 36"  
Wide Drawers Only)

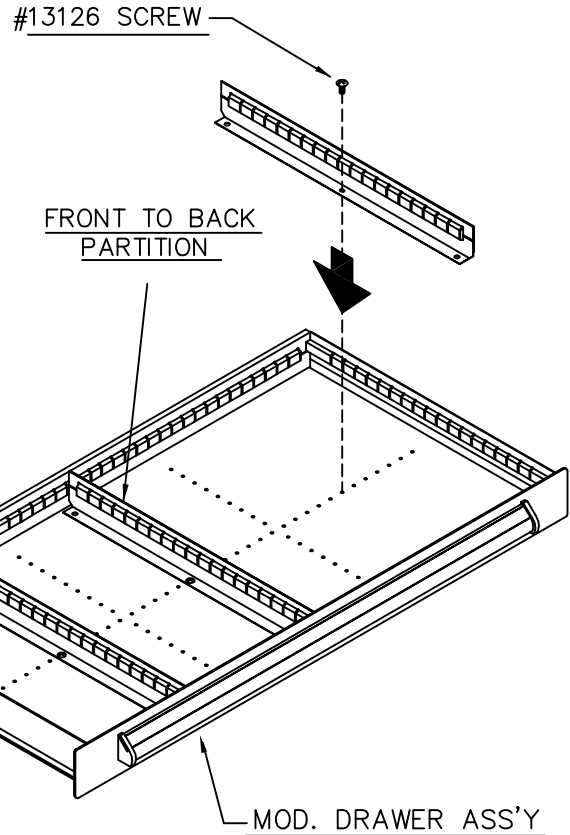
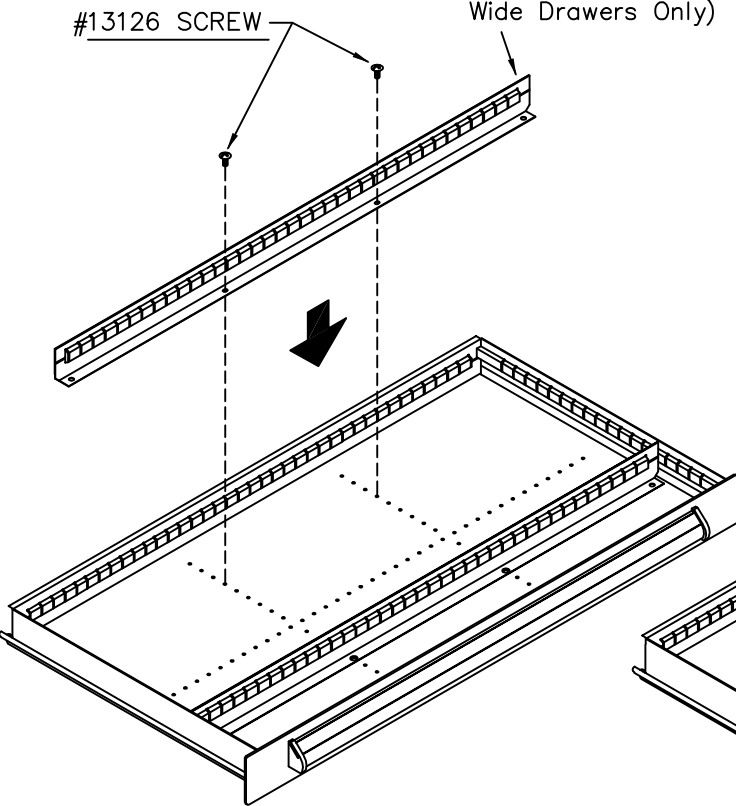

NOTE:

48" WIDE DRAWERS ARE AVAILABBLE  
IN V GRIP MOUNTING APPLICATIONS ONLY

NOTE:

IT IS RECOMMENDED THAT AT LEAST ONE FRONT  
TO BACK PARTITION BE USED TO REINFORCE THE  
48" WIDE DRAWERS TO PREVENT ANY DISHING  
EFFECT CAUSED BY CONCENTRATED LOADS

#13126 PHIL PAN HEAD THREAD  
ROLLING SCREW #8-32 X 1/4"  
(2 PER SIDE TO SIDE PARTITION)  
(1 PER FRONT TO BACK PARTITION)



FULL SCALE